



S J P N Trust's

**Hirasugar Institute of Technology, Nidasoshi**

*Inculcating Values, Promoting Prosperity*

Approved by AICTE, Recognized by Govt. of Karnataka and Affiliated to VTU Belagavi.

Accredited at 'A' Grade by NAAC

Programmes Accredited by NBA: CSE, ECE, EEE & ME

Mech. Engg. Dept.

Course Plan

IV SEM

2021-22 EVEN Sem

## *Department of Mechanical Engineering*

### **COURSE PLAN 2021-22**

### **IV Semester**



### ***INSTITUTE VISION***

“To be a preferred institution in Engineering Education by achieving excellence in teaching and research and to remain as a source of pride for its commitment to holistic development of individual and society”

### ***INSTITUTE MISSION***

"To continuously strive for the overall development of students, educating them in a state-of-the-art-infrastructure, by retaining the best practices, people and inspire them to imbibe real time problem solving skills, leadership qualities, human values and societal commitments, so that they emerge as competent professionals"



## **DEPARTMENT OF MECHANICAL ENGINEERING**

### ***VISION***

“To be the centre of excellence in providing education in the field of Mechanical Engineering to produce technically competent and socially responsible engineering graduates”

### ***MISSION***

“Educating students to prepare them for professional competencies in the broader areas of the Mechanical Engineering field by inculcating analytical skills, research abilities and encouraging culture of continuous learning for solving real time problems using modern tools”

	<b>S J P N Trust's</b> <b>Hirasugar Institute of Technology, Nidasoshi</b> <i>Inculcating Values, Promoting Prosperity</i> Approved by AICTE, Recognized by Govt. of Karnataka and Affiliated to VTU Belagavi. <b>Accredited at 'A' Grade by NAAC</b> <b>Programmes Accredited by NBA: CSE, ECE, EEE &amp; ME</b>	<b>Mech. Engg. Dept.</b>
		<b>Course Plan</b>
		<b>IV SEM</b>
		<b>2021-22 EVEN Sem</b>

### Program Educational Objectives (PEOs)

#### The Graduates will be able to

- PEO1:** Acquire core competence in Applied Science, Mathematics and Mechanical Engineering fundamentals to excel in professional career and higher study
- PEO2:** Design, demonstrate and analyze the mechanical systems which are useful to society.
- PEO3:** Maintain professional & ethical values, employability skills, multidisciplinary approach & an ability to realize engineering issues to broader social context by engaging in lifelong learning.

### Program Specific Outcomes (PSOs)

- PSO1:** Able to apply the basic principles of Mechanical Engineering in various practical fields to solve societal problems by engaging themselves in many state/national level projects.
- PSO2:** Able to analyze and design basic mechanical system using relevant tools and techniques.
- PSO3:** Able to resolve contemporary issues of industries through industry institute interaction and alumni social networks

### Program Outcomes (POs)

- PO1: Engineering knowledge-** Apply the knowledge of mathematics, science, engineering fundamentals, and an engineering specialization to the solution of complex engineering problems.
- PO2: Problem analysis-** Identify, formulate, review research literature, and analyze complex engineering problems reaching substantiated conclusions using first principles of mathematics, natural sciences, and engineering sciences.
- PO3: Design/development of solutions-** Design solutions for complex engineering problems and design system components or processes that meet the specified needs with appropriate consideration for the public health and safety, and the cultural, societal, and environmental considerations.
- PO4: Conduct investigations of complex problems-** Use research-based knowledge and research methods including design of experiments, analysis and interpretation of data, and synthesis of the information to provide valid conclusions.
- PO5: Modern tool usage-** Create, select, and apply appropriate techniques, resources, and modern engineering and IT tools including prediction and modeling to complex engineering activities with an understanding of the limitations.
- PO6: The engineer and society-** Apply reasoning informed by the contextual knowledge to assess societal, health, safety, legal and cultural issues and the consequent responsibilities relevant to the professional engineering practice.
- PO7: Environment and sustainability-** Understand the impact of the professional engineering solutions in societal and environmental contexts, and demonstrate the knowledge of, and need for sustainable development.
- PO8: Ethics-** Apply ethical principles and commit to professional ethics and responsibilities and norms of the engineering practice.
- PO9: Individual and team work-** Function effectively as an individual, and as a member or leader in diverse teams, and in multidisciplinary settings.
- PO10: Communication-** Communicate effectively on complex engineering activities with the engineering community and with society at large, such as, being able to comprehend and write effective reports and design documentation, make effective presentations, and give and receive clear instructions.
- PO11: Project management and finance-** Demonstrate knowledge and understanding of the engineering and management principles and apply these to one's own work, as a member and leader in a team, to manage projects and in multidisciplinary environments.
- PO12: Life-long learning-** Recognize the need for, and have the preparation and ability to engage in independent and life-long learning in the broadest context of technological change.

	<b>S J P N Trust's</b> <b>Hirasugar Institute of Technology, Nidasoshi</b> <i>Inculcating Values, Promoting Prosperity</i> Approved by AICTE, Recognized by Govt. of Karnataka and Affiliated to VTU Belagavi. <b>Accredited at 'A' Grade by NAAC</b> <b>Programmes Accredited by NBA: CSE, ECE, EEE &amp; ME</b>	<b>Mech. Engg. Dept.</b>
		<b>Course Plan</b>
		<b>IV SEM</b>
		<b>2021-22 EVEN Sem</b>

## CONTENTS

Sl. No.	Topic	Page No.
1	Vision and Mission	ii
2	PEOs, PSOs and POs	iii
3	Departmental Resources	v
4	Teaching Faculty Details	vi
5	Academic Calendar	vii
6	Scheme of Teaching & Examination	viii
<b>Theory Course Plan</b>		
1	Mathematics	18MAT41
2	Applied Thermodynamics	18ME42
3	Fluid Mechanics	18ME43
4	Kinematics of Machines	18ME44
5	Metal Cutting & Forming	18ME45A
6	Computer Aided Machine Drawing	18ME46A
7	CIP Ethics and Cyber Law	18CPH49
<b>Laboratory – Course Plan and Viva Questions</b>		
7	Material Testing Lab	18MEL47A
8	Workshop & Machine shop Practice	18MEL48A

	<b>S J P N Trust's</b> <b>Hirasugar Institute of Technology, Nidasoshi</b> <i>Inculcating Values, Promoting Prosperity</i> Approved by AICTE, Recognized by Govt. of Karnataka and Affiliated to VTU Belagavi. <b>Accredited at 'A' Grade by NAAC</b> <b>Programmes Accredited by NBA: CSE, ECE, EEE &amp; ME</b>	<b>Mech. Engg. Dept.</b>
		<b>Course Plan</b>
		<b>IV SEM</b>
		<b>2021-22 EVEN Sem</b>

## Departmental Resources

Department of Mechanical Engineering was established in the year 1996 and is housed in a total area of **2584.5 Sq. Meters**.

### Faculty Position

Sl. No.	Category	No. in position	Average experience
1	Teaching faculty	09	19
2	Technical staff	05	17
3	Helper / Peons	03	13

### Major Laboratories

S.N.	Name of the laboratory	Area in Sq. Meters	Amount Invested (Rs.)
1	Basic Workshop Laboratory	170	428093
2	Fluid Mechanics Machinery Laboratory	172	775916.75
3	Energy Conversion Engg. Laboratory	173	1275603.2
4	Machine shop Laboratory	170	1372566.5
5	Foundry & Forging Laboratory	179	321057.11
6	Design Laboratory	73	365861.0
7	Heat & Mass Transfer Laboratory	148	524576.0
8	Metallography & Material Testing Laboratory	149	1102945.2
9	Mechanical Measurements & Metrology Laboratory	95	557593.75
10	CIM & Automation/CAMA Laboratory	66	3720793.1
11	Computer Aided Machine Drawing Laboratory	66	2014136.5
12	Computer Aided Engg Drawing Laboratory	66	1438121.3
13	Department/Other	--	2031766.2
	<b>Total</b>	<b>1527</b>	<b>638297</b>
			<b>16567326.61</b>

	<b>S J P N Trust's</b> <b>Hirasugar Institute of Technology, Nidasoshi</b> <i>Inculcating Values, Promoting Prosperity</i> Approved by AICTE, Recognized by Govt. of Karnataka and Affiliated to VTU Belagavi. <b>Accredited at 'A' Grade by NAAC</b> <b>Programmes Accredited by NBA: CSE, ECE, EEE &amp; ME</b>	<b>Mech. Engg. Dept.</b>
		<b>Course Plan</b>
		<b>IV SEM</b>
		<b>2021-22 EVEN Sem</b>

### Teaching Faculty Details

S.N.	Faculty Name	Designation	Qualification	Area of specialization	Teaching Exp (in years)	Contact Nos.
1	Dr. S. C. Kamate	Principal	Ph. D	Thermal(Cogeneration)	31	9480849331
2	Dr. S. N. Topannavar	Assoc. Prof.	Ph. D	Thermal Power Engg.	23	9482440235
3	Dr. K. M. Akkoli	Assoc. Prof.	Ph. D	Thermal Power Engg.	18	9739114856
4	Dr. M.M.Shivashimpi	Asst. Prof	Ph. D	Thermal Power Engg.	15	9742197173
5	Prof. D. N. Inamdar	Asst. Prof	M Tech.(Ph. D)	Tool Engg	19	9591208980
6	Prof.M.S.Futane	Asst. Prof	M Tech.	Computer Integrated Manufacturing	16	9164105035
7	Prof.S. A. Goudadi	Asst. Prof	M Tech.	Design Engineering	14	9448876682
8	Prof.M.A.Hipparagi	Asst. Prof	M Tech.(Ph.D)	Production Technology	13	7411507405
9	Prof.M. I. Tanodi	Asst. Prof	M Tech. (Ph.D)	Machine design	10	9611998812
10	Prof. G. M. Zulapi	Asst. Prof	M Tech.	Product Design & Manufacturing	14	9480213587



**CALENDAR OF EVENTS FOR THE ACADEMIC YEAR 2021-22 OF II SEMESTER (EVEN)**

Date	Events																																																									
06-06-2022	Commencement of II Semester Classes	<table border="1" style="width: 100%; text-align: center;"> <tr><td colspan="7">June-2022</td></tr> <tr><td>S</td><td>M</td><td>T</td><td>W</td><td>T</td><td>F</td><td>S</td></tr> <tr><td></td><td></td><td></td><td>1</td><td>2</td><td>3</td><td>4</td></tr> <tr><td>5</td><td>6</td><td>7</td><td>8</td><td>9</td><td>10</td><td>11</td></tr> <tr><td>12</td><td>13</td><td>14</td><td>15</td><td>16</td><td>17</td><td>18</td></tr> <tr><td>19</td><td>20</td><td>21</td><td>22</td><td>23</td><td>24</td><td>25</td></tr> <tr><td>26</td><td>27</td><td>28</td><td>29</td><td>30</td><td></td><td></td></tr> </table>	June-2022							S	M	T	W	T	F	S				1	2	3	4	5	6	7	8	9	10	11	12	13	14	15	16	17	18	19	20	21	22	23	24	25	26	27	28	29	30									
June-2022																																																										
S	M		T	W	T	F	S																																																			
				1	2	3	4																																																			
5	6	7	8	9	10	11																																																				
12	13	14	15	16	17	18																																																				
19	20	21	22	23	24	25																																																				
26	27	28	29	30																																																						
14-06-2022	World Blood Donor Day																																																									
16-06-2022 to 18-06-2022	HSIT-FEST																																																									
21-06-2022	International Yoga Day																																																									
02-07-2022	Submission of Assignment-1	<table border="1" style="width: 100%; text-align: center;"> <tr><td colspan="7">July-2022</td></tr> <tr><td>S</td><td>M</td><td>T</td><td>W</td><td>T</td><td>F</td><td>S</td></tr> <tr><td></td><td></td><td></td><td></td><td></td><td>1</td><td>2</td></tr> <tr><td>3</td><td>4</td><td>5</td><td>6</td><td>7</td><td>8</td><td>9</td></tr> <tr><td>10</td><td>11</td><td>12</td><td>13</td><td>14</td><td>15</td><td>16</td></tr> <tr><td>17</td><td>18</td><td>19</td><td>20</td><td>21</td><td>22</td><td>23</td></tr> <tr><td>24</td><td>25</td><td>26</td><td>27</td><td>28</td><td>29</td><td>30</td></tr> <tr><td>31</td><td></td><td></td><td></td><td></td><td></td><td></td></tr> </table>	July-2022							S	M	T	W	T	F	S						1	2	3	4	5	6	7	8	9	10	11	12	13	14	15	16	17	18	19	20	21	22	23	24	25	26	27	28	29	30	31						
July-2022																																																										
S	M		T	W	T	F	S																																																			
						1	2																																																			
3	4		5	6	7	8	9																																																			
10	11		12	13	14	15	16																																																			
17	18		19	20	21	22	23																																																			
24	25		26	27	28	29	30																																																			
31																																																										
01-07-2022 to 03-07-2022	First Internal Assessment for II Semester																																																									
04-07-2022	Feedback-I on Teaching-Learning																																																									
07-07-2022	Display of 1 <sup>st</sup> I.A. Marks and submission of Feedback-I to office																																																									
21-07-2022	Project Exhibition																																																									
22-07-2022 to 23-07-2022	First Lab Internal Assessment for II Semester																																																									
29-07-2022	Graduation Day																																																									
31-07-2022 to 02-08-2022	Second Internal Assessment for II Semester																																																									
03-08-2022	Feedback-II on Teaching-Learning																																																									
08-08-2022	Display of 2 <sup>nd</sup> I.A. Marks and submission of Feedback-II to office	<table border="1" style="width: 100%; text-align: center;"> <tr><td colspan="7">August-2022</td></tr> <tr><td>S</td><td>M</td><td>T</td><td>W</td><td>T</td><td>F</td><td>S</td></tr> <tr><td></td><td>1</td><td>2</td><td>3</td><td>4</td><td>5</td><td>6</td></tr> <tr><td>7</td><td>8</td><td>9</td><td>10</td><td>11</td><td>12</td><td>13</td></tr> <tr><td>14</td><td>15</td><td>16</td><td>17</td><td>18</td><td>19</td><td>20</td></tr> <tr><td>21</td><td>22</td><td>23</td><td>24</td><td>25</td><td>26</td><td>27</td></tr> <tr><td>28</td><td>29</td><td>30</td><td>31</td><td></td><td></td><td></td></tr> </table> <p>9-Last Day of Moharam, 15-Independence Day            31-Varasiddhi Vinayaka Vrata</p>	August-2022							S	M	T	W	T	F	S		1	2	3	4	5	6	7	8	9	10	11	12	13	14	15	16	17	18	19	20	21	22	23	24	25	26	27	28	29	30	31										
August-2022																																																										
S	M		T	W	T	F	S																																																			
	1		2	3	4	5	6																																																			
7	8		9	10	11	12	13																																																			
14	15		16	17	18	19	20																																																			
21	22		23	24	25	26	27																																																			
28	29		30	31																																																						
13-08-2022	Submission of Assignment-2																																																									
13-08-2022	<b>TECHNOVISION -2K22</b>																																																									
25-08-2022 to 27-08-2022	Third Internal Assessment for II Semester																																																									
27-08-2022 to 30-08-2022	Second Lab Internal Assessment for II Semester																																																									
31-08-2022	Last working day of II Semester																																																									
02-09-2022	Display of Final IA Marks	<table border="1" style="width: 100%; text-align: center;"> <tr><td colspan="7">September-2022</td></tr> <tr><td>S</td><td>M</td><td>T</td><td>W</td><td>T</td><td>F</td><td>S</td></tr> <tr><td></td><td></td><td></td><td></td><td>1</td><td>2</td><td>3</td></tr> <tr><td>4</td><td>5</td><td>6</td><td>7</td><td>8</td><td>9</td><td>10</td></tr> <tr><td>11</td><td>12</td><td>13</td><td>14</td><td>15</td><td>16</td><td>17</td></tr> <tr><td>18</td><td>19</td><td>20</td><td>21</td><td>22</td><td>23</td><td>24</td></tr> <tr><td>25</td><td>26</td><td>27</td><td>28</td><td>29</td><td>30</td><td></td></tr> </table>	September-2022							S	M	T	W	T	F	S					1	2	3	4	5	6	7	8	9	10	11	12	13	14	15	16	17	18	19	20	21	22	23	24	25	26	27	28	29	30								
September-2022																																																										
S	M		T	W	T	F	S																																																			
					1	2	3																																																			
4	5		6	7	8	9	10																																																			
11	12	13	14	15	16	17																																																				
18	19	20	21	22	23	24																																																				
25	26	27	28	29	30																																																					
02-09-2022 to 09-09-2022	Practical/Viva Examination of II Semester																																																									
12-09-2022 to 30-09-2022	Theory Examination of II Semester																																																									
01-10-2022 to 20-10-2022	Intra/Inter Internship																																																									
 Dr. B. V. Madiggond Dean (Acad)		 Dr. S. C. Kamate Principal																																																								

- Note:**
1. Academic Calendar may be modified based on guidelines/directions issued in the future by competent authority.
  2. The syllabus should be completed in offline classes to cover 80% of the syllabus and 20% of the syllabus can be covered in virtual (online) mode. Attendance of the students for offline and online classes is mandatory and records should be maintained and submitted to whenever informed.



## VTU Scheme of Teaching and Examination

VISVESVARAYA TECHNOLOGICAL UNIVERSITY, BELAGAVI												
Scheme of Teaching and Examination 2018 – 19												
Outcome Based Education(OBE) and Choice Based Credit System (CBCS)												
(Effective from the academic year 2018 – 19)												
IV SEMESTER												
Sl. No	Course and Course Code	Course Title	Teaching Department	Teaching Hours /Week			Examination				Credits	
				Theory Lecture	Tutorial	Practical/ Drawing	Duration in hours	CIE Marks	SEE Marks	Total Marks		
				L	T	P						
1	BSC 18MAT41	Mathematics	Mathematics	2	2	--	03	40	60	100	3	
2	PCC 18ME42	Applied Thermodynamics		3	2	--	03	40	60	100	4	
3	PCC 18ME43	Fluid Mechanics		3	0	--	03	40	60	100	3	
4	PCC 18ME44	Kinematics of Machines		3	0	--	03	40	60	100	3	
5	PCC 18ME45A	Metal cutting and forming		3	0	--	03	40	60	100	3	
		18ME45B	Metal Casting and Welding									
6	PCC 18ME46A or 18ME46B	Computer Aided Machine Drawing/		1	4	--	03	40	60	100	3	
		Mechanical Measurements and Metrology		3	0							
7	PCC 18MEL47A or 18MEL47B	Material Testing lab		--	2	2	03	40	60	100	2	
		Mechanical Measurements and Metrology lab										
8	PCC 18MEL48A	Workshop and Machine Shop Practice (Consists of Fitting, and Machining)		--	2	2	03	40	60	100	2	
		18MEL48B	Foundry, Forging and Welding lab									
9	HSMC	18KVK49/49	Vyavaharika Kannada (Kannada for communication)/	HSMC	--	2	--	100	--	100	1	
		18KAK49/49	Aadalitha Kannada (Kannada for Administration)									
		OR										
		18CPH49	Constitution of India, Professional Ethics and Cyber Law									
<b>TOTAL</b>												
					17	10		24	420	480		
					OR	OR	04	OR	OR	OR	900	24
					19	14		27	360	540		

18KVK39 Vyavaharika Kannada (Kannada for communication) is for non-kannada speaking, reading and writing students and 18KAK39 Aadalitha Kannada (Kannada for Administration) is for students who speak, read and write kannada.

**Course prescribed to lateral entry Diploma holders admitted to III semester of Engineering programs**

10	NCCM	18MATDIP31	Additional Mathematics - I	Mathematics	02	01	--	03	40	60	100	0
----	------	------------	----------------------------	-------------	----	----	----	----	----	----	-----	---

(a) The mandatory non – credit courses Additional Mathematics I and II prescribed for III and IV semesters respectively, to the lateral entry Diploma holders admitted to III semester of BE/B.Tech programs, shall attend the classes during the respective semesters to complete all the formalities of the course and appear for the University examination. In case, any student fails to register for the said course/ fails to secure the minimum 40 % of the prescribed CIE marks, he/she shall be deemed to have secured F grade. In such a case, the student has to fulfil the requirements during subsequent semester/s to appear for SEE.

(b) These Courses shall not be considered for vertical progression, but completion of the courses shall be mandatory for the award of degree.

**Courses prescribed to lateral entry B. Sc degree holders admitted to III semester of Engineering programs**

Lateral entrant students from B.Sc. Stream, shall clear the non-credit courses Engineering Graphics and Elements of Civil Engineering and Mechanics of the First Year Engineering Programme. These Courses shall not be considered for vertical progression, but completion of the courses shall be mandatory for the award of degree.





<b>Subject Title</b>	<b>COMPLEX ANALYSIS, PROBABILITY AND STATISTICAL</b>		
<b>Subject Code</b>	18MAT41	<b>IA Marks</b>	40
<b>Number of Lecture Hrs / Week ( L:T:P)</b>	(2:2:0)	<b>Exam Marks</b>	60
<b>Total Number of Lecture Hrs</b>	45	<b>Exam Hours</b>	03
<b>CREDITS – 03</b>			

<b>FACULTY DETAILS:</b>		
<b>Name:</b> Dr. S. L. Patil	<b>Designation:</b> Asst. Professor	<b>Experience:</b> 13
<b>No. of times course taught:</b> 04	<b>Specialization:</b> Mathematics	

### 1.0 Prerequisite Subjects:

Sl. No	Branch	Semester	Subject
01	Mechanical Engineering	III	Engineering Mathematics-III

### 2.0 Course Objectives

- To provide an insight into applications of complex variables, conformal mapping and special functions arising in potential theory, quantum mechanics, heat conduction and field theory.
- To develop probability distribution of discrete, continuous random variables and joint probability distribution occurring in digital signal processing, design engineering and microwave engineering.

### 3.0 Course Outcomes

Having successfully completed this course, the student will be able to draw and use modeling software's to generate

	Course Outcome	POs
CO1	Use the concepts of analytic function and complex potentials to solve the problems arising in Electromagnetic field theory.	1,2,3,12
CO2	Utilize conformal transformation and complex integral arising in aerofoil theory, fluid flow Visualization and image processing.	1,2,3,12
CO3	Apply discrete and continuous probability distributions in analyzing the probability models arising in engineering field.	1,2,3,12
CO4	Make use of the correlation and regression analysis to fit a suitable mathematical model for the Statistical data.	1,2,3,12
CO5	Construct joint probability distributions and demonstrate the validity of testing the hypothesis.	1,2,3,12
<b>Total Hours of instruction</b>		<b>40</b>



## 4.0 Course Content

### MODULE-I

**Calculus of complex functions:** Review of function of a complex variable, limits, continuity, and differentiability. Analytic functions: Cauchy-Riemann equations in Cartesian and polar forms and consequences.

**Construction of analytic functions:** Milne-Thomson method-Problems. (09 Hours)

### MODULE-II

**Conformal transformations:** Introduction Discussion of transformations  $w = z^2, w = e^z, w = z + \frac{1}{z}$  ( $z \neq 0$ ). Bilinear transformations- Problems.

**Complex integration:** Line integral of a complex function-Cauchy's theorem and Cauchy's integral formula and Problems. (09 Hours)

### MODULE-III

**Probability Distributions:** Review of basic probability theory. Random variables (discrete and continuous), Probability mass/density functions. Binomial, Poisson, exponential and normal distributions- problems (No derivation for mean and standard deviation)-Illustrative examples. (09 Hours)

### MODULE-IV

**Statistical Methods:** Correlation and regression-Karl Pearson's coefficient of correlation and rank correlation -problems. Regression analysis- lines of regression -problems.

**Curve Fitting:** Curve fitting by the method of least squares- fitting the curves of the form-  
 $y = ax + b, y = ax^b$  and  $y = ax^2 + bx + c$  (09 Hours)

### MODULE-V

**Joint probability distribution:** Joint Probability distribution for two discrete random variables, expectation and covariance.

**Sampling Theory:** Introduction to sampling distributions, standard error, Type-I and Type-II errors. Test of Hypothesis for means, student's t-distribution, Chi-square distribution as a test of goodness of fit. (09 Hours)

## 5.0 Relevance to future subjects

Sl No	Semester	Subject	Topics
01	Common to all	Common to all engineering Subjects	Signal and Analysis, Field Theory, Thermodynamics, Fluid Dynamics etc

## 6.0 Relevance to Real World

Sl. No	Real World Mapping
01	Calculus of complex functions is used to solve engineering problems. For examples will be drawn from a variety of engineering problems, including heat transfer, vibrations, dynamics, fluid mechanics, etc.
02	Probability Distributions used to design and Analysis of algorithm, interpreting data, Machine learning and artificial intelligence
03	Sampling Theory are used in design engineering, Sensors, image scanning, electricity generation & Quality of the products

## 7.0 Gap Analysis and Mitigation

Sl. No	Delivery Type	Details
01	Tutorial	Topic: Sampling Theory



## 8.0 Books Used and Recommended to Students

### Text Books

1. B.S. Grewal: Higher Engineering Mathematics, Khanna Publishers, 44<sup>th</sup> Edition, 2017.
2. E. Kreyszig: Advanced Engineering Mathematics, John Wiley & Sons, 10<sup>th</sup> Edition, 2016
3. Srimanta Pal et al: Engineering Mathematics, Oxford University Press, 3<sup>rd</sup> Edition, 2016

### Reference Books

1. N.P. Bali and Manish Goyal: A Text Book of Engineering Mathematics, Laxmi Publishers, 2014.
2. B.V. Ramana: "Higher Engineering Mathematics" Tata McGraw-Hill, 2006.
3. C. Ray Wylie, Louis C. Barrett: Advanced Engineering Mathematics, McGraw-Hill, 6<sup>th</sup> Edition 1995
4. S.S. Sastry: Introductory Methods of Numerical Analysis, Prentice Hall of India 4<sup>th</sup> Edition 2010
5. Chandrika Prasad and Reena Garg : Advanced Engineering Mathematics, Khanna Publishing, 2018
6. H. K. Dass and Er. Rajnish Verma: "Higher Engineering Mathematics", S. Chand publishing, 1st edition, 2011.

### Additional Study material & e-Books

1. N.P. Bali & Manish Goyal, A Text book of Engineering Mathematics, 7<sup>th</sup> edition, Laxmi Publications.

## 9.0 Relevant Websites (Reputed Universities and Others) for Notes/Animation/Videos Recommended

### Website and Internet Contents References

1. <http://nptel.ac.in/courses.php?disciplineID=111>
2. <http://www.khanacademy.org/>
3. <http://www.class-central.com/subject/math>

## 10.0 Magazines/Journals Used and Recommended to Students

Sl.No	Magazines/Journals	website
1	+ Plus Magazine	<a href="https://plus.maths.org/issue44">https://plus.maths.org/issue44</a> .
2	Mathematics Magazine	<a href="http://www.mathematicsmagazine.com">www.mathematicsmagazine.com</a>

## 11.0 Examination Note

### Internal Assessment: 40 Marks

Theoretical aspects as well as relevant sketches should be drawn neatly.

### Scheme of Evaluation for Internal Assessment (30 Marks)

- (a) Internal Assessment test in the same pattern as that of the main examination  
(All the three Internal Tests marks considered): **30** Marks.
- (b) Assignments: **10** Marks

### SCHEME OF EXAMINATION:

#### Question paper pattern:

**Note:** -The SEE question paper will be set for 100 marks and the marks will be proportionately reduced to 60.

1. The question paper will have **ten** full questions carrying equal marks.
2. Each full question consisting of **20** marks.
3. There will be **two** full questions (with a **maximum** of **four** sub questions) from each module.
4. Each full question will have sub question covering all the topics under a module.
5. The students will have to answer **five** full questions, selecting **one** full question from each module.



## 12.0 Course Delivery Plan

Module	Lecture No.	Content of Lecturer	% of Portion
MODULE 1	1.	Review of a function of a complex variable, limits, continuity, differentiability	20
	2.	Analytic functions-Cauchy-Riemann equation in Cartesian form	
	3.	Problems	
	4.	Cauchy-Riemann equation in Polar form	
	5.	Problems	
	6.	construction of analytic functions	
	7.	Properties of Cauchy-Riemann equation	
	8.	Milne-Thomson method	
MODULE 2	9.	Conformal Transformations and discussion of transformations of $w = z^2$ , $w = e^z$	20
	10.	Discussion of Transformations: $w = z + (1/z)$ .	
	11.	Bilinear transformations	
	12.	Problems	
	13.	Complex line integrals-Cauchy's theorem	
	14.	Cauchy's integral formula	
	15.	Residue, poles	
	16.	Cauchy's Residue theorem	
MODULE 3	17.	Random variables (discrete and continuous)	20
	18.	Probability mass/density functions	
	19.	Binomial distribution.	
	20.	Problems	
	21.	Poisson distribution.	
	22.	Problems	
	23.	Exponential distribution.	
	24.	Normal distributions.	
MODULE 4	25.	Statistical Methods: Review of measures of central tendency and dispersion	20
	26.	Correlation-Karl Pearson's coefficient of correlation	
	27.	Problems	
	28.	Regression analysis- lines of regression (without proof) –problems	
	29.	Curve fitting by the method of least squares, of the form, form $y = ax + b$ ,	
	30.	Curve fitting by the method of least squares: $y = a + bx + cx^2$	
	31.	Problems.	
	32.	Curve fitting by the method of least squares $y = ae^{bx}$	
MODULE 5	33.	Joint Probability distribution for two discrete random variables	20
	34.	Expectation, covariance.	
	35.	Sampling & Sampling distributions	
	36.	standard error, test of hypothesis for means and proportions	
	37.	confidence limits for means	
	38.	Problems.	
	39.	student's t-distribution	
	40.	Chi-square distribution as a test of goodness of fit.	

## 13.0 QUESTION BANK

### MODULE-1: Calculus of complex functions

1. Derive Cauchy-Riemann equations in the Cartesian form.
2. Derive Cauchy-Riemann equations in the Polar form.
3. P.T if  $f(z) = u + iv$  is an analytic then the family of curves  $u(x,y) = C_1$ ,  $v(x,y) = C_2$ ,  $C_1$  &  $C_2$  being Constants, intersect each other orthogonally
4. S.T  $w = \log z$ ,  $z \neq 0$  is analytic & find  $\frac{dw}{dz}$ .



5. Find the analytic function  $f(z)$  as a function of  $z$  given that the sum of its real & imaginary parts is
6.  $x^3 + y^3 + 3xy(x - y)$
7. Determine the analytic function Whose imaginary part is  $r^2 \cos 2\theta$
8. Determine the analytic function Whose real part is  $\frac{2\cos x \cosh y}{\cos 2x + \cosh 2y}$
9. Find the analytic function  $f(z) = u + iv$  given  $u - v = e^x(\cos y - \sin y)$
10. If  $f(z)$  analytic show that  $\left[ \frac{\partial^2}{\partial x^2} + \frac{\partial^2}{\partial y^2} \right] |f(z)|^2 = 4|f'(z)|^2$

### MODULE-2: Conformal transformations

1. Discuss the conformal transformation of  $w = z^2$
2. Discuss the conformal transformation of  $w = e^z$
3. Find the bilinear transformation which map the points  $z = 1, i, -i$  under this transformation find the image of  $|z| < 1$ .
4. Find the bilinear transformation which maps  $z = \infty, i, 0$  into  $w = -1, -i, 1$ . Also find the pts of transformation
5. State & prove Cauchy integral Theorem.
6. Verify Cauchy's theorem for the function  $f(z) = z^2$  where  $c$  is the square having vertices
7.  $(0,0), (1,0), (1,1)$  &  $(0,1)$
8. Evaluate  $\int \frac{e^z}{z + i\pi} dz$  over each of the following contours  $C$ , a)  $|z| = 2\pi$ , b)  $|z| = \pi/2$ , c)  $|z - 1| = 1$
9. State & prove Cauchy integral Theorem.

### MODULE-3: Probability Distributions

1. Find the mean & variance of Binomial distribution.
2. The marks of 1000 students in an examination follows in a normal distribution with mean 70 & SD 5. Find the number of students whose marks will be i) less than 65, ii) more than 75 & iii) between 65 & 75.
3. The probability mass function of a variate  $X$  is
 

$X = x_i$	-2	-1	0	1	2	3
$p(x)$	0.1	K	0.2	2k	0.3	k
4. Find i) The value of K, ii)  $p(x \leq 0)$ , iii)  $p(x > 1)$  iv)  $p(-2 < x \leq 1)$
5. If 10% of the rivets produced by a machine are defective, find the probability that, out of 12 rivets chosen at random.
6. S.T mean & standard deviation of exponential distribution are equal.
7. In a test of 2000 electric bulbs, it was found that the life of a bulb is a normal variable with average life of 2040 hours & standard deviation of 60 hours. Estimate the number of bulbs to burn for i) More than 2150 hours, ii) less than 1950 hours, Given that  $p[0 \leq z \leq 1.83] = 0.4664$  &  $p[0 \leq z \leq 1.33] = 0.4082$ .
8. 2% of the fuses manufactured by a firm are found to be defective. Find the probability that a box containing 200 fuses contains i) no defective fuse, ii) 3 or more defective fuses.
9. In length of a telephone conversation is an exponential variate with mean 3 minutes. Find the probability that call i) ends in less than 3 minutes, ii) takes between 3 to 5 minutes.
10. Suppose that the student IQ scores form a normal distribution with average 100 & standard deviation 20. Find the percentage of students whose (i) score less than 80 (ii) score more than 120 (iii) score falls between 80 & 120 (G T  $P(1) = 0.3413$ )
11. In a certain town the duration of a shower is exponentially distributed with mean 5 minutes what is the probability that a shower will last for i) 10 minutes or more, ii) less than 10 minutes, iii) betn 10 min & 12 min



12. The probability that a person aged 60 years will live upto 70 is 0.65. what is the probability that out of 10 persons aged 60 atleast 7 of them will live upto 70.

### MODULE-4: Statistical Methods

- 1) Find the correlation coefficient and regration lines of y and x and x and y for the following data

x	1	2	3	4	5
y	2	5	3	8	7

- 2) Find the coefficient of correlation for the following data.

x	10	14	18	22	26	30
y	18	12	24	6	30	36

- 3) Compute the rank correlation coefficient for the following data

x	68	64	75	50	64	80	75	40	55	64
y	62	58	68	45	81	60	68	48	50	70

- 4) Ten students got the following % of marks in two subjects x and y. Compute their rank correlation coefficient.

Marks in x	78	36	98	25	75	82	90	62	65	39
Marks in y	84	51	91	60	68	62	86	58	53	47

### Curve Fitting and Optimization:

- 1) Find the equation of the best fitting straight line for the data

x	0	1	2	3	4	5
y	9	8	24	28	26	20

- 2) A simply supported beam carries a concentrated load p at its midpoint corresponding to various Values of p the maximum deflection y is measured & is given below

p	100	120	140	160	180	200
y	0.45	0.55	0.60	0.70	0.80	0.85

Find the law of the form  $y = a+bp$  & hence estimate y when  $p = 150$ .

- 3) Fit a second degree parabola of best fit  $y = a+bx+cx^2$

x	1.0	1.5	2.0	2.5	3.0	3.5	4.0
y	1.1	1.3	1.6	2.0	2.7	3.4	4.1

- 4) Fit a second degree parabola  $y = ax^2+bx+c$  in the least square sense for the following data

x	0	1	2	3	4
y	1	1.8	1.3	2.5	2.3

- 5) Fit a least square geometric curve  $y = ax^b$  from the following data

x	1	2	3	4	5
y	0.5	2.0	4.5	8.0	12.5

- 6) The voltage v across a capacitor at time t sec is given by the following table

t	0	2	4	6	8
v	150	63	28	12	5.6

Use the method of least square of to fit a curve of the form  $v = ae^{kt}$  to this data

### MODULE-5: Joint probability distribution:

- Explain the following terms i) Null hypothesis , ii) Level of significance , iii) Type I & II errors , iv) Confidence limits.
- A sample of 100 days is taken from meteorological records of certain districts & 10 of them are found to be fussy. Find the 99.73 % confidence interval of the % of fussy days in the distinct.
- A certain stimulus administered to each of the 12 patients resulted in the following blood pressure 5,2,8,-1,3,0,6,-2,1,5,0,4, can it be calculated that stimulus will increase the blood pressure ?  
[ $t_{0.05}$  for 11d.f= 2.201]
- A die was thrown 9000 times & a throw of 5 or 6 was obtained 3240 times. On the assumption of random throwing, do the data abdicate that the die is biased?



5. A random sample of 100 records deaths in past year showed an average life span of 71.8 years. Assuming a population standard deviation of 8.9 years, does the data indicated that average life span today is greater than 70 years? Use a 0.05 level of significance.
6. In 324 throws of a six faced die, an odd number turned up 181 times. Is it reasonable to think that the die is an unbiased one?
7. Four coins are tossed 100 times & the following results were obtained

No. of Heads	0	1	2	3	4
Frequencies	5	29	36	25	5

Fit a Binomial distribution for the data & test the goodness of fit given

$$\chi^2_{0.05} = 9.49 \text{ for 4 d. f}$$

8. Find the student's 't' for the following variable values in a sample of eight -4,-2,-2,0,2,2,3,3 taking the mean of the universe to be zero.
9. A coin was tossed 400 times & the head turned up 216 times. Test the hypotheses that the coin is in biased at 5% level significance.
10. A die was thrown 1200 times & the number 6 was obtained 236 times. Can the die be considered fair at level of significance?
11. The joint probability distribution for two random variables X and Y is as given below.

Y X	-2	-1	4	5
1	0.1	0.2	0	0.3
2	0.2	0.1	0.1	0

Find the marginal distributions of X, Y. Also find the covariance of X and Y.

12. The Joint probability distribution of two random variables X and Y is as follows

Y X	-4	2	7
1	1/8	1/4	1/8
5	1/4	1/8	1/8

13. Determine (i) Marginal distribution of X & Y (ii)  $E(X)$ ,  $E(Y)$  and  $E(XY)$  (iii)  $Cov(XY)$  (iv)  $\rho(XY)$ .
14. A fair coin is tossed 4 times. Let X denotes the number of heads occurring and let Y denotes the longest string of heads occurring. Find the joint distribution function of X and Y.

<b>Prepared by</b>	<b>Checked by</b>		
<b>Dr. S. L. Patil</b>	<b>Dr. S. L. Patil</b>	<b>HOD</b>	<b>Principal</b>



<b>Subject Title</b>	<b>APPLIED THERMODYNAMICS</b>		
<b>Subject Code</b>	18ME42	<b>IA Marks</b>	40
<b>No of Lecture Hrs + Tutorials Hrs / Week</b>	03 L+ 02 T	<b>Exam Marks</b>	60
<b>Total No of Lecture + Tutorial Hrs</b>	50	<b>Exam Hours</b>	03
<b>CREDITS – 04</b>			

<b>FACULTY DETAILS:</b>		
<b>Name:</b> Dr. S.C. Kamate	<b>Designation:</b> Professor & Principal	<b>Experience:</b> 28 Years
<b>No. of times course taught:</b> 06	<b>Specialization:</b> Thermal Power Engineering	
<b>Name:</b> Dr. M. M. Shivashimpi	<b>Designation:</b> Assistant Professor	<b>Experience:</b> 14 Years
<b>No. of times course taught:</b> 12	<b>Specialization:</b> Thermal Power Engineering	

## 1.0 Prerequisite Subjects

Sl. No	Branch	Semester	Subject
01	Mechanical Engineering	I, II & III	Engineering Mathematics
02	Mechanical Engineering	III	Basic Thermodynamics

## 2.0 Course Objectives

- To understand the applications of the first and second laws of Thermodynamics to various gas processes and cycles.
- To understand fundamentals of I. C. Engines, Construction and working Principle of an Engine and Compare Actual, Fuel-Air and Air standard cycle Performance.
- To study Combustion in SI and CI engines and its controlling factor in order to extract maximum power.
- To know the concepts of testing of I. C. Engines and methods to estimate Indicated, Brake and Frictional Power and efficiencies.
- To understand theory and performance Calculation of Positive displacement compressor.
- To understand the concepts related to Refrigeration and Air conditioning.
- To get conversant with Psychrometric Charts, Psychrometric processes, human comfort conditions.

## 3.0 Course Outcomes

Having successfully completed this course, the student will be able to

CO	Course Outcome	Cognitive Level	POs
C217.1	Apply thermodynamic concepts to analyze the performance of gas power cycles and Understand combustion of fuels and performance of I C engines.	L2,L3	PO1,P02,P04, PO6.P07,PO12
C217.2	Apply thermodynamic concepts to analyze the performance of gas power cycles including propulsion systems.	L3	PO1,P02,P04, PO7,PO12
C217.3	Apply thermodynamic concepts to analyze the performance of vapor power cycles.	L3	PO1,P02,P04, PO7,PO12
C217.4	Understand the principles and applications of refrigeration systems. Apply Thermodynamic concepts to determine performance parameters of refrigeration and air-conditioning systems.	L2,L3	PO1,P02,P04, PO6.P07,PO12
C217.5	Understand the working principle of Air compressors and Steam nozzles, applications, relevance of air and identify methods for performance	L2,L3	PO1,P02,PO3, PO6,PO12
<b>Total Hours of instruction</b>		<b>50 Hours</b>	





## 4.0 Course Content

### Module - I

**Air standard cycles:** Carnot, Otto, Diesel, Dual and Stirling cycles, p-v and T -s diagrams, description, efficiencies and mean effective pressures. Comparison of Otto and Diesel cycles.

**I.C.Engines:** Classification of IC engines, Combustion of SI engine and CI engine, Detonation and factors affecting detonation, Performance analysis of I.C Engines, Heat balance, Morse test, IC Engine fuels, Ratings and Alternate Fuels. **10 Hours**

### Module –II

**Gas power Cycles:** Gas turbine (Brayton) cycle; description and analysis. Regenerative gas turbine cycle. Intercooling and reheating in gas turbine cycles. Introduction to Jet Propulsion cycles. **10 Hours**

### Module –III

**Vapour Power Cycles:** Carnot vapour power cycle, drawbacks as a reference cycle. Simple Rankine cycle; description, T-S diagram, analysis for performance. Comparison of Carnot and Rankine cycles. Effects of pressure and temperature on Rankine cycle performance.

Actual vapour power cycles. Ideal and practical regenerative Rankine cycles, open and closed feed water heaters. Reheat Rankine cycle. Characteristics of an Ideal working fluid in vapour power cycles. **10 Hours**

### Module –IV

**Refrigeration Cycles:** Vapour compression refrigeration system; description, analysis, refrigerating effect. Capacity, power required units of refrigeration, COP, Refrigerants and their desirable properties, alternate Refrigerants. Air cycle refrigeration; reversed Carnot cycle, reversed Brayton cycle, vapour absorption refrigeration system.

**Psychrometrics and Air-conditioning Systems:** Psychrometric properties of Air, Psychrometric Chart, Analyzing Air-conditioning Processes; Heating, Cooling, Dehumidification and Humidification, Evaporative Cooling. Adiabatic mixing of two moist air streams. Cooling towers. **10 Hours**

### Module –V

**Reciprocating Compressors:** Operation of a single stage reciprocating compressors. Work input through p-v diagram and steady state steady flow analysis. Effect of Clearance and Volumetric efficiency. Adiabatic, Isothermal and Mechanical efficiencies. Multi-stage compressor, saving in work, Optimum intermediate pressure, Inter-cooling, Minimum work for compression.

**Steam nozzles:** Flow of steam through nozzles, Shape of nozzles, effect of friction, Critical pressure ratio, Supersaturated flow. **10 Hours**

## 5.0 Relevance to future subjects

Sl. No	Semester	Subject	Topics / Relevance
01	VIII	Project work	Application of IC engine, turbine, Compressor, Refrigeration and air-conditioning
02	V	Turbo machines	Euler's turbine equation, Steam turbine, compressor, pump and hydraulic turbine
03	VI	Heat and Mass Transfer	Boiling and condensation, Heat Exchanger

## 6.0 Relevance to Real World

SL. No	Real World Mapping
01	Application of IC Engine, Power generation from Gas turbine and steam turbine.
02	Analysis of actual cycle with reference of ideal cycles.
03	Design of air conditioners, compressor.
04	Actual analysis of combustion process in the IC engine, steam turbines, Gas turbines.
05	To control the environmental pollution.

## 7.0 Gap Analysis and Mitigation

Sl. No	Delivery Type	Details
01	Tutorial	Solving the unsolved problems from the reference and text books and demonstration in



		laboratory
02	Nptel.ac.in	E- Learning
03	VTU, E- learning	E- Learning
04	MOOCS	E- Learning
05	Open courseware	E- Learning

## 8.0 Books Used and Recommended to Students

<b>Text Books</b>
1. Engineering Thermodynamics, P.K. Nag, Tata McGraw Hill, 6 <sup>th</sup> Edition 2018. 2. Applications of Thermodynamics, V.Kadambi, T. R.Seetharam, K. B. Subramanya Kumar, Wiley Indian Private Ltd, 1 <sup>st</sup> Edition 2019. 3. Thermodynamics, Yunus A, Cengel, Michael A Boles, Tata McGraw Hill, 7 <sup>th</sup> Edition
<b>Reference Books</b>
1. Thermodynamics for engineers, Kenneth A. Kroosand Merle C. Potter, Cengage Learning, 2016. 2. Principles of Engineering Thermodynamics, Michael J, Moran, Howard N. Shapiro, Wiley, 8 <sup>th</sup> Edition. 3. An Introduction to ThermoDynamics, Y.V.C.Rao, Wiley Eastern Ltd, 2003. 4. Thermodynamics, Radhakrishnan, PHI, 2 <sup>nd</sup> revised edition. 5. I.C Engines, Ganeshan.V, Tata McGraw Hill, 4 <sup>th</sup> Edi. 2012. 6. I.C.Engines, M.L.Mathur& Sharma, Dhanpat Rai& sons- India.
<b>Additional Study material &amp; e-Books</b>
1. Applied Thermodynamics by R.K Hedge and Niranjan Murthy 2. Thermal Engineering by R K. Rajput 3. Applied Thermodynamics by Kestur and Pravin

## 9.0 Relevant Websites (Reputed Universities and Others) for Notes/Animation/Videos Recommended

<b>Website and Internet Contents References</b>
1. <a href="https://www.youtube.com/watch?v=G02aeguJBwc">https://www.youtube.com/watch?v=G02aeguJBwc</a> 2. <a href="https://www.youtube.com/watch?v=CU28a-5Ker8">https://www.youtube.com/watch?v=CU28a-5Ker8</a> 3. <a href="https://www.youtube.com/watch?v=vu9aNXlhbEI">https://www.youtube.com/watch?v=vu9aNXlhbEI</a> 4. <a href="https://www.youtube.com/watch?v=ub86Dhg67tM">https://www.youtube.com/watch?v=ub86Dhg67tM</a> 5. <a href="https://www.youtube.com/watch?v=e2IryaMQQ6A">https://www.youtube.com/watch?v=e2IryaMQQ6A</a> 6. VTU, E- learning 7. <a href="http://auto.howstuffworks.com">http://auto.howstuffworks.com</a>

## 10.0 Magazines/Journals Used and Recommended to Students

Sl. No	Magazines/Journals	website
1	Applied Thermal Engineering	<a href="http://www.sciencedirect.com/science/journal/13594311">http://www.sciencedirect.com/science/journal/13594311</a>
2	Case Studies in Thermal Engineering	<a href="http://www.sciencedirect.com/science/journal/2214157X">http://www.sciencedirect.com/science/journal/2214157X</a>
3	Auto car India Magazine	<a href="http://www.autocarindia.com/Magazine/">http://www.autocarindia.com/Magazine/</a>
4	<b>Low-Tech magazines</b>	<a href="http://www.lowtechmagazine.com/">http://www.lowtechmagazine.com/</a>
5	<b>Thermal News</b>	<a href="http://www.thermalnews.com/main/">http://www.thermalnews.com/main/</a>

## 11.0 Examination Note

**Internal Assessment: (30 marks for I.A. + 10 marks for assignment) = 40 Marks**

### SCHEME OF EXAMINATION:

- The question paper will have ten full questions carrying equal marks.
- Each full question will be for 20 marks.
- There will be two full questions (with a maximum of four sub- questions) from each module.
- Each full question will have sub- question covering all the topics under a module.
- The students will have to answer five full questions, selecting one full question from each module.



## 12.0 Course Delivery Plan

Module	Lecture No.	Content of Lecturer	% of Portion
<b>I</b>		<b>Air standard cycles and I.C. Engines</b>	20
	1	Carnot and Otto cycles, p-v and T -s diagrams, description, efficiencies and mean effective pressures.	
	2	Diesel and Dual cycles, p-v and T -s diagrams, description, efficiencies and mean effective pressures.	
	3	Stirling cycle, p-v and T -s diagrams, description, efficiency and mean effective pressure, Comparison of Otto and Diesel cycles.	
	4	Solving related numericals.	
	5	Solving related numericals.	
	6	Classification of IC engines, Combustion of SI engine and CI engine.	
	7	Detonation and factors affecting detonation, Performance analysis of I.C Engines.	
	8	Heat balance, Morse test, IC Engine fuels, Ratings and Alternate Fuels.	
	9	Solving related numericals.	
<b>II</b>		<b>Gas power Cycles</b>	40
	11	Gas turbine (Brayton) cycle.	
	12	Description and analysis of Regenerative gas turbine cycle.	
	13	Description and analysis of inter cooling in gas turbine cycle.	
	14	Description and analysis of reheating in gas turbine cycle.	
	15	Introduction to Jet Propulsion cycles.	
	16	Solving related numericals.	
	17	Solving related numericals.	
	18	Solving related numericals.	
	19	Solving related numericals.	
<b>III</b>		<b>Vapour Power Cycles</b>	60
	21	Carnot vapour power cycle, drawbacks as a reference cycle. Simple Rankine cycle; description, T-s diagram, analysis for performance.	
	22	Comparison of Carnot and Rankine cycles. Effects of pressure and temperature on Rankine cycle performance.	
	23	Actual vapour power cycles. Ideal and practical regenerative Rankine cycles.	
	24	Open and closed feed water heaters. Reheat Rankine cycle.	
	25	Characteristics of an Ideal working fluid in Vapour power cycles.	
	26	Solving related numericals.	
	27	Solving related numericals.	
	28	Solving related numericals.	
	29	Solving related numericals.	
<b>IV</b>		<b>Refrigeration Cycles and Psychrometrics &amp; Air-conditioning Systems</b>	80
	31	Vapour compression refrigeration system; description, analysis, refrigerating effect. Capacity, power required, units of refrigeration, COP.	
	32	Refrigerants and their desirable properties, alternate Refrigerants. Air cycle refrigeration.	
	33	Reversed Carnot cycle, reversed Brayton cycle, Vapour absorption refrigeration system.	
	34	Solving related numericals	
	35	Solving related numericals	
	36	Psychometric properties of Air, Psychometric Chart.	
	37	Analyzing Air-conditioning Processes; Heating, Cooling, Dehumidification and Humidification.	
	38	Evaporative Cooling. Adiabatic mixing of two moist air streams. Cooling towers.	
	39	Solving related numericals	
40	Solving related numericals		
<b>V</b>		<b>Reciprocating Compressors and Steam nozzles</b>	100



41	Operation of a single stage reciprocating compressors. Work input through p-v diagram and steady state steady flow analysis.
42	Effect of Clearance and Volumetric efficiency. Adiabatic, Isothermal and Mechanical efficiencies.
43	Multi-stage compressor, saving in work, Optimum intermediate pressure, Inter-cooling, Minimum work for compression.
44	Solving related numericals.
45	Solving related numericals.
46	Solving related numericals.
47	Flow of steam through nozzles.
48	Shape of nozzles, effect of friction.
49	Critical pressure ratio, Supersaturated flow.
50	Solving related numericals.

## 13.0 QUESTION BANK

### Module 1: Air standard cycles and I.C. Engines

1. Derive the expression for the air standard efficiency of Diesel cycle with usual notations. State the assumptions made and represent the process on P-V and T-S diagram.
2. Compare Otto cycle and Diesel cycles, on the basis of the same compression ratio and same maximum pressure.
3. Compare Otto cycle and Diesel cycles, with help of PV and TS diagrams, based on the following conditions. i) When max. Cycle pressure and temp. are same. ii) When the compression ratio and heat addition are same.
4. With help of p-v and T-S diagrams, derive the expression for air standard efficiency of a semi diesel cycle or limited pressure cycle or dual cycle in terms of C.R. Cut of ratio and expansion ratio.
5. Derive the expression for the air standard efficiency of Otto cycle with usual notations. State the assumptions made and represent the process on P-V and T-S diagram.
6. List the methods used for finding out indicated power of internal combustion engine. Explain the method applicable to multi cylinder engine.
7. Briefly classify the IC engines.
8. Explain the combustion phenomenon of SI engine and CI engine.
9. Define detonation. What are the factors affecting for detonation?
10. What do you understand by Air standard cycle?

### Numericals:

1. A Carnot cycle using air as the working substance works between temperature limits of 900 K and 300 K. The pressure limits are 60 bars and 1 bar. Determine (i) pressure at salient points of the cycle, (ii) the heat supplied per unit mass of air, (iii) net work output per unit mass of air, (iv) mean effective pressure and (v) thermal efficiency of the cycle.
2. The following data refers to an ideal sterling cycle with ideal regenerator. Pressure, temperature and volume of the working medium at the beginning of the volume of the cycle are 1110 of the initial volume. The maximum temperature attained in the cycle is 700°C. Draw PV and T-S diagrams. Calculate. i. The net work. ii. Thermal efficiency with 100% regenerator efficiency. iii. Thermal efficiency without the regenerator.
3. An ideal Otto cycle has a compression ratio of 8. The conditions at the beginning of compression stroke are 100 kPa and 17° C. If the heat added during the cycle is 800 kJ/kg find (i) temperatures and pressures at salient points of the cycle, (ii) net work output per unit mass of air, (iii) thermal efficiency of the cycle, (iv) mean effective pressure, (v) compression ratio corresponding to maximum work output, (vi) maximum work output and (vii) thermal efficiency corresponding to maximum work output.
4. An air standard diesel cycle has a compression ratio of 14. The air-condition at the beginning of compression is 1 bar and 27° C. The maximum temperature in the cycle is 2500° C. Determine (i) temperature and pressure at salient points of the cycle (ii) net work output per unit mass of air, (iii) thermal efficiency (iv) specific air consumption in kg/kWh and (v) MEP.
5. The pressures on the compression curve of a diesel engine are at 1/8<sup>th</sup> stroke 1.4 bar and at 7/8<sup>th</sup> stroke 14 bar. Estimate the compression ratio. Calculate the air standard efficiency and mean effective pressure of the engine if the cut-off occurs at 1/15<sup>th</sup> of the stroke. Assume initially air is at 1 bar and 27°C.
6. A four stroke, four cylinder petrol engine of 250mm bore and 375mm stroke works on the Otto cycle. The clearance volume is 0.01052m<sup>3</sup>. The initial pressure and temperature are 1bar and 47°C. If the maximum pressure is limited to 25bar, find the following: i) Air standard efficiency ii) Mean effective pressure.
7. A six cylinder, gasoline engine operates on the four stroke cycle. The bore of each cylinder is 80 mm and the stroke is 100 mm. The clearance volume in each cylinder is 70 cc. At a speed of 4000 rpm and the fuel consumption is 20 kg/h. The torque developed is 150 N-m. Calculate (i) the brake power, (ii) the brake mean effective pressure, (iii)



- brake thermal efficiency if the calorific value of the fuel is 43000 kJ/kg and (iv) the relative efficiency if the ideal cycle for the engine is Otto cycle.
8. The following observations have been made from the test of a four cylinder, two stroke petrol engine. Diameter of the cylinder = 10 cm; stroke = 15 cm; speed = 1600 rpm; Area of indicator diagram = 5.5 cm<sup>2</sup>; Length of the indicator diagram = 55 mm; spring constant = 3.5 bar/cm; Determine the indicated power of the engine.
  9. An eight cylinder, four stroke engine of 9 cm bore, 8 cm stroke and with a compression ratio of 7 is tested at 4500 rpm on a dynamometer which has 54 cm arm. During a 10 minute test, the dynamometer scale beam reading was 42 kg and the engine consumed 4.4 kg of gasoline having a calorific value of 44,000 kJ/kg. Air at 27° C and 1 bar was supplied to the carburetor at a rate of 6 kg/min. Find (i) the brake power, (ii) the brake mean effective pressure, (iii) the brake specific fuel consumption (iv) the brake specific air consumption (v) volumetric efficiency (vi) the brake thermal efficiency and (vii) the air fuel ratio.
  10. During a trial of 60 minutes on a single, cylinder on engine having cylinder dia. 300 mm stroke 450 mm and working on two stroke cycle, the following observation were made. Total fuel used = 9.6 litres, Calorific value of fuel = 45000 kJ/kg, Total number of revolutions = 12624, Gross mean effective pressure = 7.24 bar, Pumping mean effective pressure = 0.34 bar, Net load on brake = 3150 Newton, Diameter of brake drum = 1.78 m, Diameter of rope = 40 mm, Cooling water circulated = 545 liters, Cooling water temperature rise = 25°C, Specific gravity of oil = 0.8, Heat carried away by the exhaust gases = 15% total heat supplied. Determine IP, BP and mechanical efficiency. Draw up the heat balance sheet on minute basis.
  11. The following data were obtained from a Morse test on a 4-cylinder, 4-stroke cycle SI engine coupled to a hydraulic dynamometer, operating a constant speed of 1500 rpm. Brake load with all four cylinders firing = 296 N Brake load with cylinder No.1 not firing = 201 N Brake load with cylinder No.2 not firing = 206 N Brake load with cylinder No.3 not firing = 192 N Brake load with cylinder No.4 not firing = 200 N The brake power in kW is calculated using the equation  $BP = \frac{WN}{42300}$ , where W is the brake load in Newton's and N is the speed of the engine in rpm. Calculate i) Brake power ii) Indicated power iii) Friction power iv) Mechanical efficiency.
  12. During a test on a single cylinder 4 stroke oil engine the following observations were made Bore = 30cm, stroke = 45cm, duration of trial = 1hr, total fuel consumption = 7.6kg calorific value of fuel = 45,000 kJ/kg, total revolutions made = 12000, mean effective pressure 6 bar, net brake load = 1.47 kN. Brake drum diameter 1.8m rope diameter 3cm. Mass of jacket cooling water circulated = 550kg water enters at 150°C water leaves at 600°C. Total air consumption 360kg room temperature 200°C, exhaust gas temperature = 300°C. Calculate: i) Indicated and brake power; ii) Indicated thermal efficiency; iii) Mechanical efficiency; iv) Draw the heat balance sheet on minute basis.

### Module 2: Gas Power Cycles

1. Explain the with neat sketches of Turbojet, turboprop, Ramjet and turbofan engines.
2. With neat T-S diagram explain the following i) inter cooling ii) reheating ii) regeneration.
3. Differentiate between open and closed gas turbines.
4. Discuss the Jet propulsion and rocket propulsion.
5. Derive an expression for the optimum pressure ratio, for the maximum network output, in a Brayton cycle. What is the corresponding cycle efficiency?
6. What are the methods of improving the efficiency of Brayton cycle?

### Numericals :

1. An air standard Brayton cycle has air entering the compressor at 100kPa and 27 ° C. The pressure ratio is 10 and the maximum allowable temperature in the cycle is 1350 K. Determine (i) temperatures at salient points of the cycle, (ii) compressor and turbine work per unit mass of air, (iii) net work output and work ratio, (iv) thermal efficiency of the cycle, (v) specific air consumption in kg/kWh, and (vi) improvement in the thermal efficiency of the cycle if a regenerator with 100 % effectiveness is incorporated in the cycle.
2. Determine the net work output and thermal efficiency of an ideal gas turbine cycle having two stages of compression with inter cooling in between the stages and two stages of expansion with reheating in between the stages. The overall pressure ratio for the cycle is 4 and the maximum cycle temperature is 900° C Assume that the atmospheric temperature is 15° C and the cycle is designed for maximum work output. Draw the schematic and T-s diagrams for the cycle. What would be the improvement in the thermal efficiency if an ideal regenerator is incorporated in the cycle?
3. The pressure ratio of an open cycle gas turbine cycle is 6. The compressor inlet conditions are 1 bar and 15 ° C. The maximum temperature in the cycle is 800 °C. The isentropic efficiency of compressor is 85 % and that of the turbine is 90%. The combustion efficiency is 95 %. There is a pressure drop of 2 % of the inlet pressure in the combustion chamber. The calorific value of the fuel used is 42,000kJ/kg. Assuming that the values of Cp remain same throughout the cycle and equal to 1.4 and 1.005 kJ/(kg-K) respectively determine (i) net work output per unit mass of air, (ii) air-fuel ratio, (iii) thermal efficiency of the plant, (iv) specific fuel consumption in kg/kWh, and (v) power output from the plant for a mass flow rate of air of 1.0 kg/s.
4. In a reheat gas turbine cycle, comprising one compressor and two turbines, air is compressed from 1 bar, 27°C to 6 bar. The highest temperature in the cycle is 900°C. The expansion in the first stage turbine is such that the work from it just equals the work required by the compressor. Air is reheated between the two stages of expansion to 850°C. Assume that the isentropic efficiency of the compressor, the first stage and the second stage turbines are 85% each and that the working substance is air. Calculate the cycle efficiency,.



- Air enters the compressor of an ideal air standard Brayton Cycle at 100 kPa, 300K with a volumetric flow rate of  $6\text{m}^3/\text{s}$ . The compressor pressure ratio is 10. The turbine inlet temperature is 1500K. Determine. i) The thermal efficiency. ii) Work ratio iii) Power developed.
- In a gas turbine plant working on Brayton cycle with a regenerator of 75% effectiveness, the air at the inlet to the compressor is at 0.1 MPa, 30°C, the pressure ratio is 6 and the maximum cycle temperature is 900°C. If the turbine and compressor have each an efficiency of 80%, find the percentage increase in the cycle efficiency due to regeneration.
- In an open cycle gas turbine plant air enters the compressor at 1 bar and 27°C. The pressure after compression is 4 bar. The isentropic efficiencies of the turbine and the compressor are 85% and 80% respectively. Air fuel ratio is 80:1. Calorific value of the fuel used is 42000 KJ /kg. Mass flow rate of air is 2.5 kg/s. Determine the power output from the plant and the cycle efficiency. Assume that 'Cp' and  $\gamma$  to be same for both air and products of combustion. \
- The air enters the compressor of an open cycle constant pressure gas turbine at a pressure of 1bar and temperature 20°C. The pressure of the air after compression is 4 bar. The isentropic efficiencies of compressor and turbine are 80% and 85% respectively. The air-fuel ratio used is 90: 1. The flow rate of air is 3 kg/s. C.V = 420000 kJ/kg is used  $C_p = 1.005 \text{ kJ/kg K}$ ,  $\gamma = 1.4$  assume CP and r remains same for air and gases. Find i) Power developed ii) Thermal efficiency of the cycle.

### Module 3: Vapour Power Cycles

- Sketch the flow diagram and corresponding temperature – entropy of a reheat cycle and derive an expression for reheat cycle efficiency. What are the advantages gained by the steam between stages?
- Draw the line diagram and T-S diagram for vapor power cycle practical regenerative Rankine cycle with closed feed water heaters.
- Draw the line diagram and T-S diagram for vapor power cycle practical regenerative Rankine cycle with open feed water heaters.
- Explain with T-S diagrams, limitations of Carnot cycle and how we can overcome the same in Rankine cycle.
- Discuss the effect of i) Boiler pressure and ii) Condenser pressure, on the performance of a Rankine cycle

### Numericals :

- In a simple Rankine cycle, steam conditions at the boiler exit are 10 bar and 300° C. In the pipe line between the boiler exit and turbine inlet, there is an energy loss of 50 kJ/kg and a drop in pressure of 0.5 bars. The steam expands in the turbine to a pressure of 0.09 bars. The isentropic efficiency of the turbine is 0.86 and that of the pump is 0.70. Determine (i) the condition of steam entering the turbine, (ii) actual pump work per unit mass of water, (iii) turbine work per unit mass of steam (iv) net work output and thermal efficiency of the cycle, and (v) quality of steam entering the condenser.
- In a reheat steam cycle, the boiler exit conditions are 25 bar and 300 ° C. The exit pressure of steam at the end of first stage is 5 bar. The steam is then reheated to 300 ° C before expanding in the second turbine to 0.05 bar. Assuming the high and low pressure turbines to have efficiencies of 87% and 85 % respectively, find (i) the thermal energy input in the reheater, (ii) the cycle efficiency (iii) specific steam consumption and (iv) power output for a mass flow rate of 2 kg/s.
- Compare the performance of an ideal reheat cycle with that of a simple Rankine cycle in terms of (i) net work output (ii) thermal efficiency (iii) steam rate and (iv) quality of steam entering the condenser assuming the following data. Boiler exit conditions are 15 bars and 300 C. Condenser pressure is 0.1 bars. Reheating pressure is 4bar. The steam is reheated at constant pressure back to its original temperature in the reheater.
- In a reheat cycle, steam at 500°C expands in a HP turbine till it is saturated vapour. It is then reheated at constant pressure to 400°C and then expanded in a LP turbine to 40°C. If the maximum moisture content at the turbine exhaust is limited to 15% find, i) the reheat pressure ii) the pressure of steam at the inlet to the HP turbine iii) the net specific work output iv) the cycle efficiency v) the steam rate. Assume all the ideal processes.
- Steam, from a boiler enters a turbine at 25 bars and expands to condenser pressure of 0.2 bar. Determine the Rankine cycle efficiency neglecting pump work i) When steam is 80% dry at turbine inlet ii) When steam is saturated at turbine inlet iii) When steam is superheated at turbine inlet iv) Represent above 3 processes on same T-S diagram.

### Module 4: Refrigeration Cycles and Psychrometrics & Air-conditioning Systems

- Draw neat P-V and T-S diagrams for reversed Brayton cycle and derive COP.
- What is one ton of refrigeration?
- Distinguish between refrigeration and refrigerator.
- Write note on properties of refrigerants.
- With a neat sketch, describe the clearly the working of a Bell – Coleman cycle.
- Derive an expression for an Air refrigeration system.
- Explain the effect of superheat and sub cooling on the vapour compression cycle with the help of T-S and p-h diagrams.
- With a neat sketch, explain the working of vapour absorption refrigeration system.
- With a schematic diagram, explain the summer air conditioning system for hot and wet weather
- With a neat schematic diagram, explain the working of winter air conditioning system. Represent the processes on psychometric chart.



11. Define i) Specific humidity ii) degree of saturation iii) relative humidity.
12. With neat sketch describe the a summer air condition system
13. Represent the following processes on psychrometric chart i) Heating and humidifying ii) sensible heating iii) sensible cooling iv) cooling and dehumidifying.

**Numericals :**

1. A reversed Carnot cycle is used for heating and cooling. The work supplied is 10 kW. If the COP is 3.5 for cooling determine (i) the ratio of maximum temperature to minimum temperature in the cycle (ii) refrigeration effect in tons and (iii) COP if the cycle is used as a heat pump.
2. An ideal air refrigeration cycle has the following specifications: Pressure of air at compressor inlet = 101 kPa; Pressure of air at turbine inlet = 404 kPa; Temperature of air at compressor inlet =  $-6^{\circ}\text{C}$ ; Temperature of air at turbine inlet =  $27^{\circ}\text{C}$ ; Determine (i) The COP of the cycle, (ii) Power required to produce 1 ton of refrigeration, and (iii) air circulation rate per ton of refrigeration.
3. In an air refrigerating machine, the compressor takes in air at 1 bar and  $10^{\circ}\text{C}$ . After compression to 5.5 bar, the air is cooled to  $30^{\circ}\text{C}$  before expanding it back to 1 bar. Assuming ideal conditions, determine (i) refrigeration effect per unit mass of air (ii) heat rejected by air per unit mass in the intercooler and (ii) COP of the cycle, In an actual plant using the above cycle, the air flow rate is 1700 kg / h and the relative COP of the actual plant is 0.65. Determine the power required for the actual plant for the same refrigerant.
4. In a saturated vapour compression refrigeration cycle operating between an evaporator temperature of  $-10^{\circ}\text{C}$  and a condenser temperature of  $40^{\circ}\text{C}$ , the sub enthalpy of the refrigerant, Freon-12 at the end of compression is 220 kJ /kg. ease Show the cycle on T-S and p-h planes. Calculate i) COP ii) refrigerating capacity and compressor power assuming a refrigerating flow rate of 1 kg/min.
5. For a hall to be air-conditioned, the following conditions are given: Outdoor conditions:  $40^{\circ}\text{DBT}$ ,  $20^{\circ}\text{C WBT}$ , required comfort condition  $20^{\circ}\text{C WBT}$ , 60% RH. Seating capacity of the hall is 1500, amount of outdoor air supplied =  $0.3\text{ m}^3/\text{min}$  per person. If the required condition is achieved first by adiabatic humidification and then by cooling, estimate i) the capacity of the cooling coil in tones and ii) the capacity of the humidifier in kg/h.
6. Moist air at  $35^{\circ}\text{C}$  has dew point of  $15^{\circ}\text{C}$ . Calculate its relative humidity, specific humidity and enthalpy. Take  $C_{p_v} = 1.88\text{ KJ/kg K}$ . 7.  $30\text{ m}^3/\text{min}$ . of air at  $15^{\circ}\text{C DBT}$  and  $13^{\circ}\text{C WBT}$  is mixed  $12\text{ m}^3/\text{min}$ . of air at  $25^{\circ}\text{C DBT}$  and  $18^{\circ}\text{C WBT}$ . Calculate DBT, specific humidity of mixture. Take atm. Pressure as 760 mm of Hg. Calculate by calculation method only.
7. A sling psychrometer reads  $40^{\circ}\text{C D.B.T}$  and  $28^{\circ}\text{C W.B.T}$ . calculate the following. i) Specific humidity ii) Relative humidity iii) Vapour density in air iv) Dew point temperature v) Enthalpy of mixture per kg of dry air.

**Module 5: Reciprocating Compressors and Steam nozzles**

1. Derive an expression for work done in a reciprocating air compressor i) without clearance ii) with clearance.
2. What is the purpose of multi staging in reciprocating compressor?
3. Derive an expression for work done for single stage, single acting reciprocating compressor with clearance volume
4. Derive an expression for the condition for the minimum work input, required for a two stage compressor, with perfect inter cooling.
5. What are the draw backs of a single stage compressor for producing high pressure? How are these overcome by multistage compression?
6. Show that for a multistage compressor  $Z = (P_x + 1/P_1)^{1/x}$  where  $Z$  = stage pressure ratio,  $x$  = number of stages,  $(P_x + 1/P_1)$  overall pressure ratio.
7. Explain the following types of flow in a nozzle i) Frictionless adiabatic flow ii) Frictional adiabatic flow iii) Super saturated flow.
8. What is critical pressure ratio? Derive an expression for pressure ratio which gives maximum discharge through the nozzle.

**Numericals:**

1. A double acting compressor, with a piston displacement of  $0.05\text{ m}^3$  per stroke, operates at 500 rpm. The clearance is 5 percent and it receives air at 100 KPa and discharges at 600 KPa. The compression is polytropic according to the law  $PV^{1.35} = \text{constant}$ . Determine the power required to drive the compressor and the mass of air delivered in kg/s if the suction temperature is  $27^{\circ}\text{C}$ .
2. A single acting air compressor has a cylinder of bore 15 cm and the piston stroke is 25 cm. The crank speed is 600 rpm. Air is taken from atmosphere (1 bar and  $27^{\circ}\text{C}$ ) and is delivered at 11 bars. Assuming polytropic compression of the type  $PV^{1.25} = C$ , find the power required to drive the compressor if its mechanical efficiency is 80%. The compressor has a clearance which is  $1/20^{\text{th}}$  of the stroke volume. How long will it take to deliver  $1\text{ m}^3$  of air at the compressor inlet conditions? Also find the volumetric efficiency of the compressor.
3. A reciprocating compressor has a 5 % clearance with a bore and stroke of 25 x 30 cm. The compressor operates at 500 rpm. Air enters the cylinder at  $27^{\circ}\text{C}$  and 95KPa and discharges at 2000 KPa. If the indices for both compression and expansion are equal to 1.3. Determine (i) volumetric efficiency (ii) the volume of air handled at inlet conditions in  $\text{m}^3/\text{s}$  (iii) the power required to drive the compressor if the mechanical efficiency is 90 % (iv) the mass of air delivered in kg/s, (v) the mass of air in the clearance space.



4. An air compressor takes air at 1 bar and 20° C and compresses the same according to the law  $PV^{1.2} = C$ . It then delivered to a receiver at a constant pressure of 10 bar. Determine i) Temperature at the end of compression ii) Work done and Heat Transferred during compression, per kg of air.  $R = 0.287$  KJ/kg K.
5. Two stage, single acting reciprocating air compressor, with complete intercooling atmospheric air at 1 bar and 15°C, compresses it polytropically ( $n = 1.3$ ) to 30 bar. Both cylinders have the same stroke; calculate the diameter of the HP cylinder. The diameter of the LP cylinder is 300mm.
6. Air at standard atmospheric conditions is compressed and delivered to a receiver of 0.4 m diameter and 1 m long until a final pressure of 10 atm is reached. Assuming ideal conditions with no valve pressure drops, compute the power needed to drive the compressor for (i) isothermal compression, (ii) polytropic compression with  $n = 1.32$ . Assume that the receiver temperature is maintained atmospheric throughout and filling takes place in 5 min. Atmospheric temperature is 25°C. Also calculate isothermal efficiency of the compressor.
7. The steam expands from 3 bar to 1 bar in nozzle. The initial velocity is 900 m/s and initial temperature is 150° C. Determine the exit velocity of steam: i) If expansion is isentropic in nozzle ii) the nozzle efficiency is 95 %.

**14.0 University Result**

Year	S+,S,A (FCD)	B (FC)	C,D,E (SC)	%age of passing
January /February 2021	19	06	00	100

Prepared by	Checked by		
Dr. M. M. Shivashimpi	Dr. K. M. Akkoli	HOD	Principal





<b>Subject Title</b>	<b>FLUID MECHANICS</b>		
<b>Subject Code</b>	18ME43	<b>IA Marks</b>	40
<b>No of Lecture Hrs + Tutorial Hrs / Week</b>	03+02	<b>Exam Marks</b>	60
<b>Total No of Lecture + Practical Hrs</b>	50+0	<b>Exam Hours</b>	03
<b>CREDITS – 03</b>			

<b>FACULTY DETAILS:</b>		
<b>Name:</b> Dr. S.N.Topannavar	<b>Designation:</b> Assoc. Professor	<b>Experience:</b> 22 Years
<b>No. of times course taught:</b> 9 Times		<b>Specialization:</b> Thermal Power Engg.

## 1.0 Prerequisite Subjects:

Sl. No	Branch	Semester	Subject
Mechanical Engineering	I/II/III/IV	Engg. Mathematics	Mechanical Engineering
Mechanical Engineering	III	Basic thermodynamics	Mechanical Engineering

## 2.0 Course Objectives

- To have a working knowledge of the basic properties of fluids and understand the continuum approximation.
- To calculate the forces exerted by a fluid at rest on submerged surfaces and understand the force of buoyancy.
- To understand the flow characteristic and dynamics of flow field for various engineering applications.
- To know how velocity changes and energy transfers in fluid flows are related to forces and torques and to understand why designing for minimum loss of energy in fluid flows is so important.
- To discuss laminar and turbulent flow and appreciate their differences and the concept of boundary layer theory.
- To understand the concept of dynamic similarity and how to apply it to experimental modelling.
- To appreciate the consequences of compressibility in gas flow and understand the effects of friction and heat transfer on compressible flows

## 3.0 Course Outcomes

The student, after successful completion of the course, will be able to

CO	Course Outcome	Cognitive Level	POs
CO1	Understand and Formulate the properties of fluids, static pressure on submerged body.	L3	PO1,PO2,PO6, PO9,PO12
CO2	Interpret and apply the principles of fluid buoyancy and kinematics	L3	PO1,PO2,PO4, PO9,PO12
CO3	Apply the knowledge of fluid dynamics while addressing problems of mechanical engineering and understand the laminar and turbulent flows to formulate the correlations for the different fluid flows and analysis of different losses during the flow.	L3	PO1,PO2,PO4, PO9,PO12
C04	Analyze the flow over bodies and dimensional analysis.	L4	PO1,PO2,PO3, PO6,PO12
C05	Understand the basic concepts of compressible flow and applications of CFD.	L2	PO1,PO2,PO6, PO7,PO12
<b>Total Hours of instruction</b>		<b>50</b>	



## 4.0 Course Content

### Module-1

**Basics:** Introduction, Properties of fluids-mass density, weight density, specific volume, specific gravity, viscosity, surface tension, capillarity, vapour pressure, compressibility and bulk modulus. Concept of continuum, types of fluids etc., pressure at a point in the static mass of fluid, variation of pressure. Pascal's law, absolute, gauge, atmospheric and vacuum pressures; pressure measurement by simple, differential manometers and mechanical gauges.

**Fluid Statics:** Total pressure and centre of pressure for horizontal plane, vertical plane surface and inclined plane surface submerged in static fluid.

### Module-2

**Buoyancy,** center of buoyancy, meta center and meta centric height its application.

**Fluid Kinematics:** Velocity of fluid particle, types of fluid flow, description of flow, continuity equation, Coordinate free form, acceleration of fluid particle, rotational & irrotational flow, Laplace's equation in velocity potential and Poisson's equation in stream function, flow net.

### Module-3

**Fluid Dynamics;** Introduction. Forces acting on fluid in motion. Euler's equation of motion along a streamline. Integration of Euler's equation to obtain Bernoulli's equation, Assumptions and limitations of Bernoulli's equation. Introduction to Navier-Stokes equation. Application of Bernoulli's theorem such as venturi-meter, orifice meter, rectangular and triangular notch, pitot tube.

**Laminar and turbulent flow:** Flow through circular pipe, between parallel plates, Power absorbed in viscous flow in bearings, Poiseuille equation – velocity profile loss of head due to friction in viscous flow. Reynolds's experiment, frictional loss in pipe flow. Introduction to turbulence, characteristics of turbulent flow, laminar turbulent transition major and minor losses.

### Module-4

**Flow over bodies:** Development of boundary layer, Prandtl's boundary layer equations, Blasius solution, integral momentum equation, drag on a flat plate, boundary layer separation and its control, streamlined and bluff bodies -flow around circular bodies and aero foils, calculation of lift and drag.

**Dimensional analysis:** Introduction, derived quantities, dimensions of physical quantities, dimensional homogeneity, Rayleigh's method, Buckingham Pi-theorem, dimensionless numbers, similitude, types of similitude.

### Module-5

**Compressible Flows:** Introduction, thermodynamic relations of perfect gases, internal energy and enthalpy, speed of sound, pressure field due to a moving source, basic Equations for one-dimensional flow, stagnation and sonic properties, normal and oblique shocks.

**Introduction to CFD:** Necessity, limitations, philosophy behind CFD, applications.

## 5.0 Relevance to future subjects

SL. No	Semester	Subject	Topics / Relevance
1	V	Turbo machines	Analysis, Design and Development of fluid machines
2	VI	Heat and Mass Transfer	Convection heat transfer
3	VII	Hydraulics and pneumatics	Design and Development of hydraulic and pneumatic valves
4	VIII	Power plant engineering	Fluid flow analysis in power plant equipments
5	V	Fluid Mechanics and Machinery Lab	Fluid properties and flow analysis

## 6.0 Relevance to Real World

SL. No	Real World Mapping
01	Design and Development of Fluid flow and heat transfer equipments in industries



02	Pipe net work design to distribute the fluid in industries, agriculture and society
03	Fluid flow analysis and system design for living organisms

## 7.0 Books Used and Recommended to Students

### Text Books

- 1 A Text Book of Fluid Mechanis And Hydraulic Machines Dr R.K Bansal Laxmi Publishers
- 2 Fluid Mechanics F M White McGraw Hill Publications Eighth edition. 2016
- 3 Fluid Mechanics (SI Units) Yunus A. Cengel John M.Cimbala TataMcGraw Hill 3rd Ed.,2014.

### Reference Books

- 1 Fluid Mechanics F M White McGraw Hill Publications Eighth edition. 2016
- 2 Fundamentals of Fluid Mechanics Munson, Young, Okiishi&Huebsch, John Wiley Publications 7<sup>th</sup> edition
- 3 Fluid Mechanics Pijush.K.Kundu, IRAM COCHEN ELSEVIER 3rd Ed. 2005
- 4 Fluid Mechanics John F.Douglas, Janul and M.Gasiosek and john A.Swaffield Pearson Education Asia 5<sup>th</sup> ed., 2006
- 5 Introduction to Fluid Mechanics Fox, McDonald John Wiley Publications 8<sup>th</sup> edition.

### Additional Study material & e-Books

- Nptel.ac.in
- VTU, E- learning
- MOOCS
- Open courseware

## 8.0 Relevant Websites (Reputed Universities and Others) for Notes/Animation/Videos Recommended

### Website and Internet Contents References

1. <http://www.nptel.ac.in>
2. Fluid Mechanics related websites

## 9.0 Magazines/Journals Used and Recommended to Students

Sl.No	Magazines/Journals	website
1	<b><u>International Journal of Heat transfer</u></b>	<a href="https://www.journals.elsevier.com/international-journal-of-fluid-flow-and-fluid-dynamics/">https://www.journals.elsevier.com/international-journal-of-fluid-flow-and-fluid-dynamics/</a>
2	International Journal of Thermodynamics	<a href="http://dergipark.ulakbim.gov.tr/eoguijt/">http://dergipark.ulakbim.gov.tr/eoguijt/</a>

## 10.0 Examination Note

### Internal Assessment: 30 Marks for IA Tests +10 Marks for Assignments

Theoretical aspects as well as relevant sketches should be drawn neatly for questions asked in Internal Assessments and assignments

### Scheme of Evaluation for Internal Assessment

Internal Assessment test in the same pattern as that of the main examination (Average of 3 Tests):30marks.

### SCHEME OF EXAMINATION:

- There are five modules two questions from each module
- Student has to answer any five question choosing at least one questions from each module.

Max. Marks: 60Marks

### Question paper pattern:

- The question paper will have ten full questions carrying equal marks.
- Each full question will be for 20 marks.



- There will be two full questions (with a maximum of four sub- questions) from each module.
- Each full question will have sub- question covering all the topics under a module.
- The students will have to answer five full questions, selecting one full question from each module

## 11.0 Course Delivery Plan

Module No.	Lecture No.	Content of Lecture	% of Portion
1		<b>Basics Properties of Fluids</b>	25
	1	Introduction, properties of fluids, viscosity	
	2	Thermodynamic properties, Surface tension and Capillarity	
	3	Vapour pressure and Cavitation.	
	4	Solving of related numericals.	
		<b>Fluid Statics</b>	
	5	Fluid pressure at a point, Pascal's law, pressure variation in a static fluid, Absolute, gauge, atmospheric and vacuum pressures	
	6	simple manometers, differential manometers	
	7	total pressure and center of pressure, vertical plane surface submerged in liquid,	
	8	horizontal plane surface submerged in liquid	
9	Inclined plane surface submerged in liquid curved surface submerged in liquid		
10	Solving of related numerical.		
2		<b>Buoyancy</b>	20
	1	Buoyancy, center of buoyancy,	
	2	meta-center and meta-centric height,	
	3	conditions of equilibrium of floating bodies	
	4	submerged bodies	
		<b>Fluid Kinematics</b>	
	5	Types of fluid flow,	
	6	continuity equation, continuity equation in 3 dimensions (Cartesian co-ordinate system only)	
	7	velocity and acceleration	
8	velocity potential function and stream function		
9	Solving of related numerical		
		<b>Fluid Dynamics</b>	
	1	Introduction, equations of motion, Euler's equation of motion	
	2	Bernoulli's equation from Euler's equation Bernoulli's equation for real fluids	
	3	Momentum equation, Impacts of jets- force on fixed and moving vanes, flat and curved	
	4	Introduction, venturimeter, orifice meter Pitot tube, V-Notch and rectangular notches.	
5	Solving of related numerical		
3		<b>Laminar and Turbulent flow</b>	15
	6	Reynolds Number, Entrance flow and Developed flow, Navier- Stokes Equation (no derivation) Laminar flow between parallel plates, Poiseuille equation – velocity profile, Couette flow, Fully developed laminar flow in circular pipes, Hagen - Poiseuille equation.	
	7	Solving the related problems	
	8	Frictional loss in pipe flow. Darcy- Equation for loss of head due to friction in pipes Commercial pipe, Colebrook equation	
	9	Moody equation/ diagram. Pipes in series parallel, equivalent pipe	
	10	Related Numericals and simple pipe design problems.	
4		<b>Flow over bodies:</b>	25
	1	Development of boundary layer, Prandtl's boundary layer equations,.	
	2	Blasius solution, laminar layer over a flat plate,	
3	boundary layer separation and its control. Basic concept of Lift and Drag,		



	4	Types of drag, Co-efficient of drag and lift, streamline body and bluff body,	
	5	flow around circular bodies and airfoils, Lift and drag on airfoil, Numericals.	
	<b>Dimensional analysis:</b>		
	6	Need for dimensional analysis,	
	7	Dimensions and units, Dimensional Homogeneity and dimensionless ratios,	
	8	methods of dimensional analysis, Rayleigh's method, Buckingham Pi theorem,	
	9	Similitude and Model studies. Numericals	
	10	Solving of related numericals.	
	<b>Compressible Flows:</b>		
	<b>5</b>	1	
2		thermodynamic relations of perfect gases	
3		internal energy and enthalpy, speed of sound	
4		pressure field due to a moving source	
5		basic Equations for one- dimensional flow,	
6		stagnation and sonic Properties, normal and oblique shocks	
<b>Introduction to CFD:</b>			
7		Necessity, limitations,	
8	philosophy behind CFD, applications		

## 12.0 Assignments/Pop Quiz/Mini Project/Seminars

Sl.No.	Title	Outcome expected: students able to	Allied study	Week No.	Individual / Group activity	Reference: book/website /Paper
1	Assignment 1: Questions on Introductory concepts and definitions	Solve Numericals related to CO1	Module 1	3	Individual Activity.	Text Books
2	Assignment 2: Questions on Dynamics of flow	Derive expressions and Solve Numericals related to CO2	Module 2	6	Individual Activity.	Text Books
3	Assignment 3: Questions on One-Darcy Weishach	Derive expressions and Solve Numericals related to CO3	Module 3	8	Individual Activity.	Text Books
4	Assignment 4: Questions on flow over bodies	Derive expressions and Solve Numericals related to CO4	Module 4	10	Individual Activity.	Text Books
5	Assignment 5: Compressible flow Introduction to CFD	Derive expressions and Solve Numericals related to CO5	Module 5	11	Individual Activity.	Reference book s

## 13.0 Assignment question bank

### ASSIGNMENT: 1

Date: 27.2.18

Module 1		
Q. No	Description of Question	Marks
1	Define fluid classify the same. Define (1) Fluid Mechanics, (2) Hydromechanics, (3) Fluid static, (4) Hydrostatic	5
2	Define Density, specific weight, sp.volume and sp. Gravity.	5
3	Explain capillarity and derive an expression for i) Capillary rise and ii) capillary fall depression.	5
4	State and prove Pascal's Law	5
5	Numericals: from F M White	5

### ASSIGNMENT: 2

Date: 20.3.18

Module 2		
Q. No	Description of Question	Marks



1	What are the Types of fluid flow and explain laminar and turbulent flow.	5
2	Derive an expression for continuity equation in 3 dimensions (Cartesian co-ordinate system only)	5
3	Derive an expression for Bernoulli's equation from Euler's equation	5
4	Derive an expression for venturimeter	5
5	Numerical related to Bernoulli's equation, velocity potential function and stream function and flow rate measuring devices.	5

**ASSIGNMENT: 3**

Date: 10.4.18

Module 3		
Q. No	Description of Question	Marks
1	Derive an expression for Hagen - Poiseuille equation	5
2	Solving the related problems	5
3	Derive an expression for Darcy- Equation for loss of head due to friction in pipes	5
4	Solving the related problems	5
5	Derive an expression for Laminar flow between parallel plates.	5

**ASSIGNMENT: 4**

Date: 27.4.18

Module 4		
Q. No	Description of Question	Marks
1	State Buckingham's $\pi$ theorem. The tip deflection $\delta$ of a cantilever beam is a function of tip load W, beam length l, second moment of area I and Young's modulus E. Perform a dimensional analysis of this problem.	5
2	Explain the following i) Drag ii) Lift	5
3	Explain the following i) Momentum thickness ii) Mach number iii) Mach cone	5
4	A flat plate 1.8m x1.8 m moves at 36 km/hr in stationary air of density 1.2 kg/m <sup>3</sup> . If the coefficient of drag and lift are 0.15 and 0.75 respectively. Determine: i) The lift force ii) The drag force iii) The resultant; force iv) Power required to keep the plate in motion.	5
5	Distinguish between i) Streamline body and bluff body ii) Friction drag and pressure drag.	5

**ASSIGNMENT: 5**

Date: 15.5.18

Module 5		
Q. No	Description of Question	Marks
1	Write a note on necessity of CFD.	5
2	Derive an expression for stagnation pressure	5
3	Derive an expression for stagnation density and temperature	5
4	Define stagnation density, temperature and pressure	5
5	Related numerical	5

## 14.0 QUESTION BANK

**MODULE-1: Basics Properties of Fluids and Fluid Statics**

1. Define fluid classify the same. Define (1) Fluid Mechanics, (2) Hydromechanics, (3) Fluid static, (4) Hydrostatic, (5) Fluid kinematics, (6) Hydro kinematics, (7) Fluid dynamics, (8) Hydrodynamics, (9) Hydraulics.
2. What do you mean by continuum concept of fluid?
3. Define Density, specific weight, sp. volume and sp. Gravity.
4. What is viscosity? Explain in brief. Derive an equation for absolute or dynamic viscosity and write its unit in S.I. Also define kinematics viscosity. Write its equation and S.I. Unit. Relate poise, centipoises, stoke, Centistokes with units of viscosities in S.I
5. Describe in brief thermodynamic properties of fluids.
6. Explain capillarity and derive an expression for i) Capillary rise and ii) capillary fall depression.
7. Numericals: from books
8. What is static fluid?
9. Define pressure. Derive an expression for pressure at a point below free surface of liquid. Also derive a general form of equation for pressure variation in a static fluid. Define pressure head
10. State and prove Pascal's Law.
11. Describe guagepr ; atmospheric pr, vacuum pr and absolute pr.
12. Describe mechanical guage. Sketch and explain Bourdon tube pressure guage.
13. Describe monometer. Classify it. Explain in brief (1) Piezometer, U-Tube manometer single column manometer, Differential manometer, inverted U-Tube manometer and derive their respective equations.



14. Numericals Ref FM – Pijush.K.Kundu
15. Define total or resultant pressure force and center of pressure. Derive an expression for total pressure force & position of C.P for the following conditions I) vertical plane surface submerged in liquid ii) Horizontal plane surface submerged in liquid iii) Inclined plane surface submerged in liquid.
16. Define the term buoyancy and center of buoyancy.
17. Explain the term metacentre and meta centric height.
18. Derive an analytical expression for the metacentric height of a floating body.
19. Describe in brief experimental method of determining metacentric height.
20. What are the conditions of equilibrium of a floating body and a submerged body

### MODULE-2: Fluid Kinematics and Fluid Dynamics

1. Define kinematics of flow. What are the different methods of describing fluid motion.
2. Define the following types of line: i) Path line ii) stream line iii) Stream tube iv) Potential line, v) Streak or filament line.
3. Define the following types of fluid flow: 1) steady and unsteady flow 2) Uniform and non uniform flow 3) Laminar, transition and turbulent flow 4) Compressible and incompressible flow. 5) Rotational and irrotational Flow 6) One – Two and Three dimensional Flow.
4. Define continuity equation . Write its equation Derive the continuity equation for the three dimensional flow in Cartesian co-ordinates and modify it for two and one dimensional flow.
5. Describe velocity and Acceleration of fluid particles. Also explain local acceleration and convective acceleration.
6. Describe with sketches 4 important types of motion.
7. What do you mean by velocity potential function and stream function. Also write their proper ties.
8. Explain equipotential line and line of constant stream function. Also relate stream function and velocity potential Function.
9. Numerical:
10. Name the different forces present in a Fluid flow. For the Euler's equation of motion, which forces are taken into consideration?
11. What is Euler's equation? How will you obtain Bernoulli's equation from it?
12. State Bernoulli's theorem for steady flow of an incompressible fluid. Derive an expression for Bernoulli's theorem from the first principle and state the assumptions made for such a derive. Also write it applications.
13. Numericals
14. What is venturimeter? Derive an expression for the discharge through a venturimeter.
15. What is orificemeter. Derive an expression for discharge through an orificemeter.
16. What is pitot – tube? How will you determine the velocity at any point with the help of pitot – tube?
17. What is the difference between pitot tube and pitot – static tube?
18. Numericals :
19. What is V-notch? Derive an expression for discharge through a v-notch.
20. Numericals

### MODULE-3: Laminar and turbulent flow

1. What do you mean by 'Viscous flow'
2. Derive an expression for the viscosity distribution for viscous flow through a circular pipe. Also sketch the velocity distribution and shear stress distribution across a section of the pipe.
3. Prove that maximum velocity in a circular pipe for viscous flow is equal to two times the average velocity of the flow.
4. Find the expression for the loss of head of a viscous fluid through a circular pipe.
5. What is Hagen Poisenille's formula? Drive an expression for Hagen Poisenille's formula.
6. Prove that the velocity distribution for viscous flow between two parallel plates when both plates are fixed across a section is parabolic in nature. Also prove that maximum velocity is equal to one and a half times the average velocity. Also derive an expression for drop of head for a given length of pipes.
7. Numericals:
8. What do you understand by the terms: Major energy loss and minor energy losses in pipes?
9. How will you determine the loss of head due to friction in pipes by using I) Darcy formula and ii) Chezy's formula.
10. Derive an expression for loss of head due to i) Sudden expansion of pipe ii) Sudden contraction in pipe, iii) Bend in pipe, iv) pipe fittings and v) an obstruction in pipe.
11. What is a compound pipe? What will be loss of head when pipes are connected in series?
12. Explain the term pipes in parallel. How discharge through the main pipe is increased by connecting pipes in parallel.
13. Describe flow through branched pipes.
14. Numericals



**MODULE-4: Flow over bodies:**

1. Define the term: drag and lift. Derive its expression.
2. Numericals.
3. What do you understand by the term boundary layer and boundary layer concept?
4. Define Laminal boundary Layer, Laminar sub Layer, boundary layer thickness. Derive an expression for displacement thickness and momentum thickness.
5. Numericals
6. Define the terms dimensional analysis.
7. What do you mean by fundamental Units and derived Units. Prepared a table for fundamental quantity, geometric quantity, kinematics quantity and dynamic quantity and write their symbol and dimensions. Explain the term dimensionally homogeneous equation.
8. What are the methods of dimensional analysis? Describe Rayleigh's method of dimensional analysis.
9. State Buckingham's  $\pi$  Theorem. Why this theorem is considered superior over the Rayleigh's method for dimensional analysis?
10. What do you mean by repeating variables? How are repeating variables are selected for dimensional analysis?.
11. Numericals:

**MODULE-5: Compressible Flows and Introduction to CFD:**

1. Define Char's law and boys law
2. Define Mach Number, Mach angle, Mach cone.
3. Explain pressure field due to moving source
4. Define stagnation property, normal shock, oblique shock.
5. Derive an expression for stagnation pressure, density and temperature.
6. Numericals
7. Write a note on necessity of CFD.

**15.0 University Result**

Examination	S+	S	A	B	C	D	E	% Passing
<b>July 2017</b>	00	00	03	10	22	29	27	65.51
<b>July 2018</b>	00	00	09	12	39	19	18	84.90
<b>July 2019</b>								100 (Promoted due to COVID-19 based on the 50 weight age from the previous sem and 50% weight age from the current sem IA marks))
<b>July 2020</b>			22	03				100 (Promoted due to COVID-19 based on the 50 weight age from the previous sem and 50% weight age from the current sem IA marks))

<b>Prepared by</b>	<b>Checked by</b>		
<b>Dr. S.N. Topannavar</b>	<b>-Sd- Module Coordinator</b>	<b>HOD</b>	<b>Principal</b>





<b>Subject Title</b>	<b>FLUID MECHANICS</b>		
<b>Subject Code</b>	18ME43	<b>IA Marks</b>	40
<b>No of Lecture Hrs + Tutorial Hrs / Week</b>	03+02	<b>Exam Marks</b>	60
<b>Total No of Lecture + Practical Hrs</b>	50+0	<b>Exam Hours</b>	03
<b>CREDITS – 03</b>			

<b>FACULTY DETAILS:</b>		
<b>Name:</b> Dr. S.N.Topannavar	<b>Designation:</b> Assoc. Professor	<b>Experience:</b> 22 Years
<b>No. of times course taught:</b> 9 Times		<b>Specialization:</b> Thermal Power Engg.

## 1.0 Prerequisite Subjects:

Sl. No	Branch	Semester	Subject
Mechanical Engineering	I/II/III/IV	Engg. Mathematics	Mechanical Engineering
Mechanical Engineering	III	Basic thermodynamics	Mechanical Engineering

## 2.0 Course Objectives

- To have a working knowledge of the basic properties of fluids and understand the continuum approximation.
- To calculate the forces exerted by a fluid at rest on submerged surfaces and understand the force of buoyancy.
- To understand the flow characteristic and dynamics of flow field for various engineering applications.
- To know how velocity changes and energy transfers in fluid flows are related to forces and torques and to understand why designing for minimum loss of energy in fluid flows is so important.
- To discuss laminar and turbulent flow and appreciate their differences and the concept of boundary layer theory.
- To understand the concept of dynamic similarity and how to apply it to experimental modelling.
- To appreciate the consequences of compressibility in gas flow and understand the effects of friction and heat transfer on compressible flows

## 3.0 Course Outcomes

The student, after successful completion of the course, will be able to

CO	Course Outcome	Cognitive Level	POs
CO1	Understand and Formulate the properties of fluids, static pressure on submerged body.	L3	PO1,PO2,PO6, PO9,PO12
CO2	Interpret and apply the principles of fluid buoyancy and kinematics	L3	PO1,PO2,PO4, PO9,PO12
CO3	Apply the knowledge of fluid dynamics while addressing problems of mechanical engineering and understand the laminar and turbulent flows to formulate the correlations for the different fluid flows and analysis of different losses during the flow.	L3	PO1,PO2,PO4, PO9,PO12
C04	Analyze the flow over bodies and dimensional analysis.	L4	PO1,PO2,PO3, PO6,PO12
CO5	Understand the basic concepts of compressible flow and applications of CFD.	L2	PO1,PO2,PO6, PO7,PO12
<b>Total Hours of instruction</b>		<b>50</b>	



## 4.0 Course Content

### Module-1

**Basics:** Introduction, Properties of fluids-mass density, weight density, specific volume, specific gravity, viscosity, surface tension, capillarity, vapour pressure, compressibility and bulk modulus. Concept of continuum, types of fluids etc., pressure at a point in the static mass of fluid, variation of pressure. Pascal's law, absolute, gauge, atmospheric and vacuum pressures; pressure measurement by simple, differential manometers and mechanical gauges.

**Fluid Statics:** Total pressure and centre of pressure for horizontal plane, vertical plane surface and inclined plane surface submerged in static fluid.

### Module-2

**Buoyancy,** center of buoyancy, meta center and meta centric height its application.

**Fluid Kinematics:** Velocity of fluid particle, types of fluid flow, description of flow, continuity equation, Coordinate free form, acceleration of fluid particle, rotational & irrotational flow, Laplace's equation in velocity potential and Poisson's equation in stream function, flow net.

### Module-3

**Fluid Dynamics;** Introduction. Forces acting on fluid in motion. Euler's equation of motion along a streamline. Integration of Euler's equation to obtain Bernoulli's equation, Assumptions and limitations of Bernoulli's equation. Introduction to Navier-Stokes equation. Application of Bernoulli's theorem such as venturi-meter, orifice meter, rectangular and triangular notch, pitot tube.

**Laminar and turbulent flow:** Flow through circular pipe, between parallel plates, Power absorbed in viscous flow in bearings, Poiseuille equation – velocity profile loss of head due to friction in viscous flow. Reynolds's experiment, frictional loss in pipe flow. Introduction to turbulence, characteristics of turbulent flow, laminar turbulent transition major and minor losses.

### Module-4

**Flow over bodies:** Development of boundary layer, Prandtl's boundary layer equations, Blasius solution, integral momentum equation, drag on a flat plate, boundary layer separation and its control, streamlined and bluff bodies -flow around circular bodies and aero foils, calculation of lift and drag.

**Dimensional analysis:** Introduction, derived quantities, dimensions of physical quantities, dimensional homogeneity, Rayleigh's method, Buckingham Pi-theorem, dimensionless numbers, similitude, types of similitude.

### Module-5

**Compressible Flows:** Introduction, thermodynamic relations of perfect gases, internal energy and enthalpy, speed of sound, pressure field due to a moving source, basic Equations for one-dimensional flow, stagnation and sonic properties, normal and oblique shocks.

**Introduction to CFD:** Necessity, limitations, philosophy behind CFD, applications.

## 5.0 Relevance to future subjects

SL. No	Semester	Subject	Topics / Relevance
1	V	Turbo machines	Analysis, Design and Development of fluid machines
2	VI	Heat and Mass Transfer	Convection heat transfer
3	VII	Hydraulics and pneumatics	Design and Development of hydraulic and pneumatic valves
4	VIII	Power plant engineering	Fluid flow analysis in power plant equipments
5	V	Fluid Mechanics and Machinery Lab	Fluid properties and flow analysis

## 6.0 Relevance to Real World

SL. No	Real World Mapping
01	Design and Development of Fluid flow and heat transfer equipments in industries



02	Pipe net work design to distribute the fluid in industries, agriculture and society
03	Fluid flow analysis and system design for living organisms

## 7.0 Books Used and Recommended to Students

### Text Books

- 1 A Text Book of Fluid Mechanis And Hydraulic Machines Dr R.K Bansal Laxmi Publishers
- 2 Fluid Mechanics F M White McGraw Hill Publications Eighth edition. 2016
- 3 Fluid Mechanics (SI Units) Yunus A. Cengel John M.Cimbala TataMcGraw Hill 3rd Ed.,2014.

### Reference Books

- 1 Fluid Mechanics F M White McGraw Hill Publications Eighth edition. 2016
- 2 Fundamentals of Fluid Mechanics Munson, Young, Okiishi&Huebsch, John Wiley Publications 7<sup>th</sup> edition
- 3 Fluid Mechanics Pijush.K.Kundu, IRAM COCHEN ELSEVIER 3rd Ed. 2005
- 4 Fluid Mechanics John F.Douglas, Janul and M.Gasiosek and john A.Swaffield Pearson Education Asia 5<sup>th</sup> ed., 2006
- 5 Introduction to Fluid Mechanics Fox, McDonald John Wiley Publications 8<sup>th</sup> edition.

### Additional Study material & e-Books

- Nptel.ac.in
- VTU, E- learning
- MOOCS
- Open courseware

## 8.0 Relevant Websites (Reputed Universities and Others) for Notes/Animation/Videos Recommended

### Website and Internet Contents References

3. <http://www.nptel.ac.in>
4. Fluid Mechanics related websites

## 9.0 Magazines/Journals Used and Recommended to Students

Sl.No	Magazines/Journals	website
1	<b><u>International Journal of Heat transfer</u></b>	<a href="https://www.journals.elsevier.com/international-journal-of-fluid-flow-and-fluid-dynamics/">https://www.journals.elsevier.com/international-journal-of-fluid-flow-and-fluid-dynamics/</a>
2	International Journal of Thermodynamics	<a href="http://dergipark.ulakbim.gov.tr/eoguijt/">http://dergipark.ulakbim.gov.tr/eoguijt/</a>

## 10.0 Examination Note

### Internal Assessment: 30 Marks for IA Tests +10 Marks for Assignments

Theoretical aspects as well as relevant sketches should be drawn neatly for questions asked in Internal Assessments and assignments

### Scheme of Evaluation for Internal Assessment

Internal Assessment test in the same pattern as that of the main examination (Average of 3 Tests):30marks.

### SCHEME OF EXAMINATION:

- There are five modules two questions from each module
- Student has to answer any five question choosing at least one questions from each module.

Max. Marks: 60Marks

Question paper pattern:



- The question paper will have ten full questions carrying equal marks.
- Each full question will be for 20 marks.
- There will be two full questions (with a maximum of four sub- questions) from each module.
- Each full question will have sub- question covering all the topics under a module.
- The students will have to answer five full questions, selecting one full question from each module

## 11.0 Course Delivery Plan

Module No.	Lecture No.	Content of Lecture	% of Portion
1		<b>Basics Properties of Fluids</b>	25
	1	Introduction, properties of fluids, viscosity	
	2	Thermodynamic properties, Surface tension and Capillarity	
	3	Vapour pressure and Cavitation.	
	4	Solving of related numericals.	
		<b>Fluid Statics</b>	
	5	Fluid pressure at a point, Pascal's law, pressure variation in a static fluid, Absolute, gauge, atmospheric and vacuum pressures	
	6	simple manometers, differential manometers	
	7	total pressure and center of pressure, vertical plane surface submerged in liquid,	
	8	horizontal plane surface submerged in liquid	
9	Inclined plane surface submerged in liquid curved surface submerged in liquid		
10	Solving of related numerical.		
2		<b>Buoyancy</b>	20
	1	Buoyancy, center of buoyancy,	
	2	meta-center and meta-centric height,	
	3	conditions of equilibrium of floating bodies	
	4	submerged bodies	
		<b>Fluid Kinematics</b>	
	5	Types of fluid flow,	
	6	continuity equation, continuity equation in 3 dimensions (Cartesian co-ordinate system only)	
	7	velocity and acceleration	
8	velocity potential function and stream function		
9	Solving of related numerical		
		<b>Fluid Dynamics</b>	15
	1	Introduction, equations of motion, Euler's equation of motion	
	2	Bernoulli's equation from Euler's equation Bernoulli's equation for real fluids	
	3	Momentum equation, Impacts of jets- force on fixed and moving vanes, flat and curved	
	4	Introduction, venturimeter, orifice meter Pitot tube, V-Notch and rectangular notches.	
	5	Solving of related numerical	
3		<b>Laminar and Turbulent flow</b>	15
	6	Reynolds Number, Entrance flow and Developed flow, Navier- Stokes Equation (no derivation) Laminar flow between parallel plates, Poiseuille equation – velocity profile, Couette flow, Fully developed laminar flow in circular pipes, Hagen - Poiseuille equation.	
	7	Solving the related problems	
	8	Frictional loss in pipe flow. Darcy- Equation for loss of head due to friction in pipes Commercial pipe, Colebrook equation	
	9	Moody equation/ diagram. Pipes in series	



		parallel, equivalent pipe	
	10	Related Numericals and simple pipe design problems.	
<b>4</b>		<b>Flow over bodies:</b>	<b>25</b>
	1	Development of boundary layer, Prandtl's boundary layer equations,.	
	2	Blasius solution, laminar layer over a flat plate,	
	3	boundary layer separation and its control. Basic concept of Lift and Drag,	
	4	Types of drag, Co-efficient of drag and lift, streamline body and bluff body,	
	5	flow around circular bodies and airfoils, Lift and drag on airfoil, Numericals.	
		<b>Dimensional analysis:</b>	
	6	Need for dimensional analysis,	
	7	Dimensions and units, Dimensional Homogeneity and dimensionless ratios,	
	8	methods of dimensional analysis, Rayleigh's method, Buckingham Pi theorem,	
9	Similitude and Model studies. Numericals		
10	Solving of related numericals.		
<b>5</b>		<b>Compressible Flows:</b>	<b>15</b>
	1	Introduction	
	2	thermodynamic relations of perfect gases	
	3	internal energy and enthalpy, speed of sound	
	4	pressure field due to a moving source	
	5	basic Equations for one- dimensional flow,	
	6	stagnation and sonic Properties, normal and oblique shocks	
		<b>Introduction to CFD:</b>	
7	Necessity, limitations,		
8	philosophy behind CFD, applications		

## 12.0 Assignments/Pop Quiz/Mini Project/Seminars

Sl.No.	Title	Outcome expected: students able to	Allied study	Week No.	Individual / Group activity	Reference: book/website /Paper
1	Assignment 1: Questions on Introductory concepts and definitions	Solve Numericals related to CO1	Module 1	3	Individual Activity.	Text Books
2	Assignment 2: Questions on Dynamics of flow	Derive expressions and Solve Numericals related to CO2	Module 2	6	Individual Activity.	Text Books
3	Assignment 3: Questions on One-Darcy Weishach	Derive expressions and Solve Numericals related to CO3	Module 3	8	Individual Activity.	Text Books
4	Assignment 4: Questions on flow over bodies	Derive expressions and Solve Numericals related to CO4	Module 4	10	Individual Activity.	Text Books
5	Assignment 5: Compressible flow Introduction to CFD	Derive expressions and Solve Numericals related to CO5	Module 5	11	Individual Activity.	Reference book s

## 13.0 Assignment question bank

### ASSIGNMENT: 1

Date: 27.2.18

Module 1		
Q. No	Description of Question	Marks
1	Define fluid classify the same. Define (1) Fluid Mechanics, (2) Hydromechanics, (3) Fluid static, (4) Hydrostatic	5
2	Define Density, specific weight, sp.volume and sp. Gravity.	5
3	Explain capillarity and derive an expression for i) Capillary rise and ii) capillary fall depression.	5



4	State and prove Pascal's Law	5
5	Numericals: from F M White	5

**ASSIGNMENT: 2**

Date: 20.3.18

Module 2		
Q. No	Description of Question	Marks
1	What are the Types of fluid flow and explain laminar and turbulent flow.	5
2	Derive an expression for continuity equation in 3 dimensions (Cartesian co-ordinate system only)	5
3	Derive an expression for Bernoulli's equation from Euler's equation	5
4	Derive an expression for venturimeter	5
5	Numerical related to Bernoulli's equation, velocity potential function and stream function and flow rate measuring devices.	5

**ASSIGNMENT: 3**

Date: 10.4.18

Module 3		
Q. No	Description of Question	Marks
1	Derive an expression for Hagen - Poiseuille equation	5
2	Solving the related problems	5
3	Derive an expression for Darcy- Equation for loss of head due to friction in pipes	5
4	Solving the related problems	5
5	Derive an expression for Laminar flow between parallel plates.	5

**ASSIGNMENT: 4**

Date: 27.4.18

Module 4		
Q. No	Description of Question	Marks
1	State Buckingham's $\pi$ theorem. The tip deflection $\delta$ of a cantilever beam is a function of tip load $W$ , beam length $l$ , second moment of area $I$ and Young's modulus $E$ . Perform a dimensional analysis of this problem.	5
2	Explain the following i) Drag ii) Lift	5
3	Explain the following i) Momentum thickness ii) Mach number iii) Mach cone	5
4	A flat plate 1.8m x1.8 m moves at 36 km/hr in stationary air of density 1.2 kg/m <sup>3</sup> . If the coefficient of drag and lift are 0.15 and 0.75 respectively. Determine: i) The lift force ii) The drag force iii) The resultant; force iv) Power required to keep the plate in motion.	5
5	Distinguish between i) Streamline body and bluff body ii) Friction drag and pressure drag.	5

**ASSIGNMENT: 5**

Date: 15.5.18

Module 5		
Q. No	Description of Question	Marks
1	Write a note on necessity of CFD.	5
2	Derive an expression for stagnation pressure	5
3	Derive an expression for stagnation density and temperature	5
4	Define stagnation density, temperature and pressure	5
5	Related numerical	5

**14.0 QUESTION BANK**

**MODULE-1: Basics Properties of Fluids and Fluid Statics**

21. Define fluid classify the same. Define (1) Fluid Mechanics, (2) Hydromechanics, (3) Fluid static, (4) Hydrostatic, (5) Fluid kinematics, (6) Hydro kinematics, (7) Fluid dynamics, (8) Hydrodynamics, (9) Hydraulics.
22. What do you mean by continuum concept of fluid?
23. Define Density, specific weight, sp. volume and sp. Gravity.
24. What is viscosity? Explain in brief. Derive an equation for absolute or dynamic viscosity and write its unit in S.I. Also define kinematics viscosity. Write its equation and S.I. Unit. Relate poise, centipoises, stoke, Centistokes with units of viscosities in S.I
25. Describe in brief thermodynamic properties of fluids.
26. Explain capillarity and derive an expression for i) Capillary rise and ii) capillary fall depression.
27. Numericals: from books



28. What is static fluid?
29. Define pressure. Derive an expression for pressure at a point below free surface of liquid. Also derive a general form of equation for pressure variation in a static fluid. Define pressure head
30. State and prove Pascal's Law.
31. Describe gauge pr ; atmospheric pr, vacuum pr and absolute pr.
32. Describe mechanical gauge. Sketch and explain Bourdon tube pressure gauge.
33. Describe manometer. Classify it. Explain in brief (1) Piezometer, U-Tube manometer single column manometer, Differential manometer, inverted U-Tube manometer and derive their respective equations.
34. Numericals Ref FM – Pijush.K.Kundu
35. Define total or resultant pressure force and center of pressure. Derive an expression for total pressure force & position of C.P for the following conditions I) vertical plane surface submerged in liquid ii) Horizontal plane surface submerged in liquid iii) Inclined plane surface submerged in liquid.
36. Define the term buoyancy and center of buoyancy.
37. Explain the term metacentre and meta centric height.
38. Derive an analytical expression for the metacentric height of a floating body.
39. Describe in brief experimental method of determining metacentric height.
40. What are the conditions of equilibrium of a floating body and a submerged body

### MODULE-2: Fluid Kinematics and Fluid Dynamics

21. Define kinematics of flow. What are the different methods of describing fluid motion.
22. Define the following types of line: i) Path line ii) stream line iii) Stream tube iv) Potential line, v) Streak or filament line.
23. Define the following types of fluid flow: 1) steady and unsteady flow 2) Uniform and non uniform flow 3) Laminar, transition and turbulent flow 4) Compressible and incompressible flow. 5) Rotational and irrotational Flow 6) One – Two and Three dimensional Flow.
24. Define continuity equation . Write its equation Derive the continuity equation for the three dimensional flow in Cartesian co-ordinates and modify it for two and one dimensional flow.
25. Describe velocity and Acceleration of fluid particles. Also explain local acceleration and convective acceleration.
26. Describe with sketches 4 important types of motion.
27. What do you mean by velocity potential function and stream function. Also write their proper ties.
28. Explain equipotential line and line of constant stream function. Also relate stream function and velocity potential Function.
29. Numerical:
30. Name the different forces present in a Fluid flow. For the Euler's equation of motion, which forces are taken into consideration?
31. What is Euler's equation? How will you obtain Bernoulli's equation from it?
32. State Bernoulli's theorem for steady flow of an incompressible fluid. Derive an expression for Bernoulli's theorem from the first principle and state the assumptions made for such a derive. Also write it applications.
33. Numericals
34. What is venturimeter? Derive an expression for the discharge through a venturimeter.
35. What is orificemeter. Derive an expression for discharge through an orificemeter.
36. What is pitot – tube? How will you determine the velocity at any point with the help of pitot – tube?
37. What is the difference between pitot tube and pitot – static tube?
38. Numericals :
39. What is V-notch? Derive an expression for discharge through a v-notch.
40. Numericals

### MODULE-3: Laminar and turbulent flow

15. What do you mean by 'Viscous flow'
16. Derive an expression for the viscosity distribution for viscous flow through a circular pipe. Also sketch the velocity distribution and shear stress distribution across a section of the pipe.
17. Prove that maximum velocity in a circular pipe for viscous flow is equal to two times the average velocity of the flow.
18. Find the expression for the loss of head of a viscous fluid through a circular pipe.
19. What is Hagen Poisenille's formula? Drive an expression for Hagen Poisenille's formula.
20. Prove that the velocity distribution for viscous flow between two parallel plates when both plates are fixed across a section is parabolic in nature. Also prove that maximum velocity is equal to one and a half times the average velocity. Also derive an expression for drop of head for a given length of pipes.
21. Numericals:
22. What do you understand by the terms: Major energy loss and minor energy losses in pipes?



23. How will you determine the loss of head due to friction in pipes by using i) Darcy formula and ii) Chezy's formula.
24. Derive an expression for loss of head due to i) Sudden expansion of pipe ii) Sudden contraction in pipe, iii) Bend in pipe, iv) pipe fittings and v) an obstruction in pipe.
25. What is a compound pipe? What will be loss of head when pipes are connected in series?
26. Explain the term pipes in parallel. How discharge through the main pipe is increased by connecting pipes in parallel.
27. Describe flow through branched pipes.
28. Numericals

**MODULE-4: Flow over bodies:**

12. Define the term: drag and lift. Derive its expression.
13. Numericals.
14. What do you understand by the term boundary layer and boundary layer concept?
15. Define Laminar boundary Layer, Laminar sub Layer, boundary layer thickness. Derive an expression for displacement thickness and momentum thickness.
16. Numericals
17. Define the terms dimensional analysis.
18. What do you mean by fundamental Units and derived Units. Prepared a table for fundamental quantity, geometric quantity, kinematics quantity and dynamic quantity and write their symbol and dimensions. Explain the term dimensionally homogeneous equation.
19. What are the methods of dimensional analysis? Describe Rayleigh's method of dimensional analysis.
20. State Buckingham's  $\pi$  Theorem. Why this theorem is considered superior over the Rayleigh's method for dimensional analysis?
21. What do you mean by repeating variables? How are repeating variables are selected for dimensional analysis?.
22. Numericals:

**MODULE-5: Compressible Flows and Introduction to CFD:**

8. Define Charl's law and boys law
9. Define Mach Number, Mach angle, Mach cone.
10. Explain pressure field due to moving source
11. Define stagnation property, normal shock, oblique shock.
12. Derive an expression for stagnation pressure, density and temperature.
13. Numericals
14. Write a note on necessity of CFD.

**15.0 University Result**

Examination	S+	S	A	B	C	D	E	% Passing
July 2017	00	00	03	10	22	29	27	65.51
July 2018	00	00	09	12	39	19	18	84.90
July 2019								100 (Promoted due to COVID-19 based on the 50 weight age from the previous sem and 50% weight age from the current sem IA marks))
July 2020			22	03				100 (Promoted due to COVID-19 based on the 50 weight age from the previous sem and 50% weight age from the current sem IA marks))

Prepared by	Checked by	
-------------	------------	--





S J P N Trust's

# Hirasugar Institute of Technology, Nidasoshi

*Inculcating Values, Promoting Prosperity*

Approved by AICTE, Recognized by Govt. of Karnataka and Affiliated to VTU Belagavi.

Accredited at 'A' Grade by NAAC



Programmes Accredited by NBA: CSE, ECE, EEE & ME

Mech. Engg. Dept.

Course Plan

IV SEM

2021-22

	-Sd-		
Dr. S.N. Topannavar	Module Coordinator	HOD	Principal



<b>Subject Title</b>	<b>KINEMATICS OF MACHINES</b>		
<b>Subject Code</b>	18ME44	<b>IA Marks</b>	40
<b>No of Lecture Hrs + Tutorial Hrs / Week</b>	03+01	<b>Exam Marks</b>	60
<b>Total No of Lecture + Practical Hrs</b>	50	<b>Exam Hours</b>	03
<b>CREDITS – 04</b>			

<b>FACULTY DETAILS:</b>		
<b>Name:</b> Prof. Mahantesh Tanodi	<b>Designation:</b> Asst. Professor	<b>Experience:</b> 10 Years
<b>No. of times course taught:</b> 09		<b>Specialization:</b> Machine Design

## 1.0 Prerequisite Subjects:

Sl. No	Branch	Semester	Subject
1	Mechanical Engineering	I/II	Elements of Mechanical Engineering
2	Mechanical Engineering	I/II/III/IV	Engg Mathematics
3	Mechanical Engineering	III	Mechanics of Materials

## 2.0 Course Objectives

- To understand the concept of machines, mechanisms and related terminologies.
- To expose the students to various mechanisms and motion transmission elements used in Mechanical Engineering.
- To analyze a mechanism for displacement, velocity and acceleration at any point in a moving link.
- To understand the theory of cams, gears and gear trains.

## 3.0 Course Outcomes

Having successfully completed this course, the student will be able to

CO	Course Outcome	Cognitive Level	POs	PSOs
C218.1	Identify mechanisms, their motion and understand the inversions of four bar mechanisms.	L2	PO1,PO2, PO6, PO8, PO12	PSO1,PSO2
C218.2	Comprehend velocity and acceleration analysis of planar mechanisms using graphical method, Instantaneous Center Method	L1,L2,L3,	PO1,PO2, PO6, PO8, PO12	PSO1,PSO2
C218.3	Comprehend velocity and acceleration analysis of planar mechanisms using analytical method	L1,L2,L3,	PO1,PO2, PO6, PO8, PO12	PSO1,PSO2
C218.4	Analysis of cam follower motion for the motion specifications.	L2	PO1,PO2, PO6, PO8, PO12	PSO1,PSO2
C218.5	Understand the working of the spur gears and analyze the gear trains speed ratio and torque.	L2,L3,	PO1,PO2, PO6, PO8, PO12	PSO1,PSO2
<b>Total Hours of instruction</b>			<b>50</b>	

## 4.0 Course Content

### MODULE -1

**Mechanisms:** Definitions: Link , types of links, joint, types of joints kinematic pairs, Constrained motion, kinematic chain, mechanism and types , degrees of freedom of planar mechanisms, Equivalent mechanisms, Grashoff's criteria and types of four bar mechanisms, , inversions of of four bar chain, slider crank chain, Doubler slider crank chain and its inversions, Grashoff's chain. Mechanisms: Quick return motion mechanisms Drag link mechanism, Whitworth mechanism and Crank and slotted lever Mechanism. Straight line motion mechanisms, Peaucellier's mechanism and Robert's mechanism. Intermittent Motion mechanisms: Geneva wheel mechanism, Ratchet and Pawl mechanism, toggle mechanism, pantograph, condition for correct steering, Ackerman steering gear mechanism. **(10 Hours)**



**MODULE -2**

**Velocity and Acceleration Analysis of Mechanisms (Graphical Method):** Velocity and acceleration analysis of four bar mechanism, slider crank mechanism. Mechanism illustrating Corioli's component of acceleration. Angular velocity and angular acceleration of links, velocity of rubbing.

**Velocity Analysis by Instantaneous Center Method:** Definition, Kennedy's theorem, Determination of linear and angular velocity using instantaneous center method. (10Hours)

**MODULE -3**

**Velocity and Acceleration Analysis of Mechanisms (Analytical Method):** Velocity and acceleration analysis of four bar mechanism, slider crank mechanism using complex algebra method.

**Freudenstein's equation** for four bar mechanism and slider crank mechanism.

**Function Generation** for four bar mechanism

**MODULE -4**

**Cams:** Classification of cams, Types of followers, Cam nomenclature, Follower motions and motion analysis, of SHM, Motion with uniform acceleration and deceleration, uniform velocity, cycloidal motion, Cam profile with offset knife edge follower, roller follower, flat faced follower.(10 Hours)

**MODULE -5**

**Spur Gears:** Gear terminology, law of gearing, path of contact, arc of contact, contact ratio of spur gear. Interference in involute gears, methods of avoiding interference, condition and expressions for minimum number of teeth to avoid interference.

**Gear Trains:** Simple gear trains, compound gear trains. Epicyclic gear trains: Algebraic and tabular methods of finding velocity ratio of epicyclic gear trains, torque calculation in epicyclic gear trains. (10 Hours)

**5.0 Relevance to future subjects**

SL. No	Semester	Subject	Topics / Relevance
01	VI	Design of machine element II	Gears/Cams
02	VII	Project Work	Kinematic analysis and synthesis of Mechanical parts

**6.0 Relevance to Real World**

SL. No	Real World Mapping
01	Kinematic analysis and synthesis of Mechanisms
02	Kinematic analysis and synthesis of Gears

**7.0 Books Used and Recommended to Students**

<b>Text Books</b>
1.Rattan S.S, Theory of Machines, Tata McGraw-Hill Publishing Company Ltd., New Delhi, 4 th Edition, 2014. 2.Ambekar A. G., Mechanism and Machine Theory, PHI, 2009.
<b>Reference Books</b>
1.Michael M Stanisc, Mechanisms and Machines-Kinematics, Dynamics and Synthesis, Cengage Learning, 2016. 2.Sadhu Singh, Theory of Machines, Pearson Education (Singapore)Pvt. Ltd, Indian Branch New Delhi, 2nd Edi. 2006.
<b>Additional Study material &amp; e-Books</b>
1.Nptel.ac.in 2.VTU, E- learning

**8.0 Relevant Websites (Reputed Universities and Others) for Notes/Animation/Videos Recommended**

Website and Internet Contents References



<http://www.nptel.ac.in>

## 9.0 Magazines/Journals Used and Recommended to Students

Sl.No	Magazines/Journals	website
1	<a href="https://www.journals.elsevier.com/mechanism-and-machine-theory">Mechanism and Machine Theory - Journal - Elsevier</a>	<a href="https://www.journals.elsevier.com/mechanism-and-machine-theory">https://www.journals.elsevier.com/mechanism-and-machine-theory</a>
2	<a href="http://tmm.spbstu.ru/english.html">Theory of Mechanisms and Machines: electronic journal</a>	<a href="http://tmm.spbstu.ru/english.html">tmm.spbstu.ru/english.html</a>
3	<a href="http://mechanismsrobotics.asmedigitalcollection.asme.org/journal.aspx">Mechanisms and robotics</a>	<a href="http://mechanismsrobotics.asmedigitalcollection.asme.org/journal.aspx">http://mechanismsrobotics.asmedigitalcollection.asme.org/journal.aspx</a>

## 10.0 Examination Note

Question paper pattern:

- The question paper will have ten full questions carrying equal marks.
- Each full question will be for 20 marks.
- There will be two full questions (with a maximum of four sub- questions) from each module.
- Each full question will have sub- question covering all the topics under a module.
- The students will have to answer five full questions, selecting one full question from each module.

## 11.0 Course Delivery Plan

Module No.	Lecture No.	Content of Lecture	% of Portion
1		<b>Mechanisms</b>	20
	1	Definitions: Link , types of links, joint, types of joints kinematic pairs, Constrained motion, kinematic chain	
	2	Mechanism and types , degrees of freedom of planar mechanisms, Equivalent mechanisms, Groshoff's criteria and types of four bar mechanisms	
	3	Inversions of four bar chain	
	4	Inversions of slider crank chain	
	5	Inversions of double slider crank chain Grashoff's chain	
	6	Mechanisms: Quick return motion mechanisms Drag link mechanism, Whitworth mechanism and Crank and slotted lever Mechanism	
	7	Straight line motion mechanisms, Peaucellier's mechanism and Robert's mechanism	
	8	Intermittent Motion mechanisms: Geneva wheel mechanism, Ratchet and Pawl mechanism	
	9	Toggle mechanism, pantograph,	
10	Condition for correct steering, Ackerman steering gear mechanism.		
2		<b>Velocity and Acceleration Analysis of Mechanisms (Graphical Method)</b>	20
	11	Velocity and acceleration analysis of four bar mechanism,	
	12	slider crank mechanism	
	13	Mechanism illustrating Coriolis component of acceleration	
	14	Angular velocity and angular acceleration of links, velocity of rubbing.	
	15	Velocity Analysis by Instantaneous Center Method: Definition,	
	16	Kennedy's theorem,	
	17	Determination of linear and angular velocity using instantaneous center method.	
	18	Problems	
	19	Problems	
20	Problems		
3		<b>Velocity and Acceleration Analysis of Mechanisms (Analytical Method):</b>	20
	21	Velocity and acceleration analysis of four bar mechanism using complex algebra method	
	22	slider crank mechanism using complex algebra method	
	23	slider crank mechanism using complex algebra method	
	24	Freudenstein's equation for four bar mechanism	
	25	Freudenstein's equation for slider crank mechanism.	
26	Function Generation for four bar mechanism.		



	27	Problems	
	28	Problems	
	29	Problems	
	30	Problems	
4		<b>Cams:</b>	20
	31	Classification of cams, Types of followers, Cam nomenclature,	
	32	Follower motions and motion analysis, of SHM,	
	33	Motion with uniform acceleration and deceleration, uniform velocity, cycloidal motion,	
	34	Motion with uniform acceleration and deceleration, uniform velocity, cycloidal motion,	
	35	Problems	
	36	Problems	
	37	Problems	
	38	Problems	
5		<b>Spur Gears:</b>	20
	41	Gear terminology, law of gearing	
	42	Path of contact, arc of contact, contact ratio of spur gear	
	43	Interference in involute gears, methods of avoiding interference,	
	44	Condition and expressions for minimum number of teeth to avoid interference	
	45	Solving of related numerical	
	46	<b>Gear Trains:</b> Simple gear trains, compound gear trains. Epicyclic gear trains	
	47	Algebraic methods of finding velocity ratio of epicyclic gear trains,	
	48	Solving of related numerical.	
	48	Tabular methods of finding velocity ratio of epicyclic gear trains,	
	49	Solving of related numerical.	
50	Solving of related numerical.		

## 12.0 Assignments, Pop Quiz, Mini Project, Seminars

Sl. No.	Title	Outcome expected: students able to	Allied study	Week No.	Individual / Group activity	Reference: book/website /Paper
1	<i>Assignment -1:</i> Questions on Introduction & Mechanisms	Explain Basic definitions and Mechanisms	Module 1	2	Individual Activity.	Text Book 1&2
2	<i>Assignment-2:</i> Questions on Velocity and Acceleration Analysis of Mechanisms (Graphical Method)	Analyses Velocity and Acceleration of Mechanisms by Graphical Method.	Module 2	4	Individual Activity.	Text Book 1&2
3	<i>Assignment-3:</i> Questions on Velocity and Acceleration Analysis of Mechanisms (Analytical Method)	Analyses Velocity and Acceleration of Mechanisms by Analytical Method.	Module 3	6	Individual Activity.	Text Book 1&2
4	<i>Assignment-4:</i> Cams	Explain types of cams their terminology & Analysis of cams	Module 4	8	Individual Activity.	Text Book 1&2
5	<i>Assignment-5:</i> Questions on Spur gears & gear trains	Explain Gear terminology & types of gears	Module 5	8	Individual Activity.	Text Book 1&2

## 13.0 QUESTION BANK

### MODULE-1:



### INTRODUCTION:

1. Define kinematic link, kinematic pair, and kinematic chain.
2. Distinguish between a) mechanism and machine b) completely constrained motion and successful constrained motion.
3. What is an inversion? Explain various inversions of single and double slider crank chains.
4. Discuss various types of constrained motions.
5. What are quick-return mechanisms? Where are they used? Discuss the functioning of any one of them.
6. Explain briefly elliptical trammel and scotch yoke mechanism with neat diagram.
7. Define mobility of a mechanism with example.
8. What is the difference between exact and approximate straight line mechanism. Explain each with suitable example.
9. Explain the working of the following mechanisms with neat sketch a) pantograph b) toggle mechanism c) Ackermann's steering gear mechanism d) Geneva mechanism e) Ratchet and pawl mechanism.
10. Explain the following mechanisms with suitable sketches a) drag link mechanism b) whit worth mechanism c) crank and slotted link mechanism.

### MODULE-2:

#### VELOCITY AND ACCELERATION ANALYSIS OF MECHANISMS (GRAPHICAL METHODS):

1. In mechanism shown in fig.2.1, crank 2 rotates at 3000rpm. Find the acceleration of the point C in magnitude, direction and sense. Find also the angular acceleration of link 3.

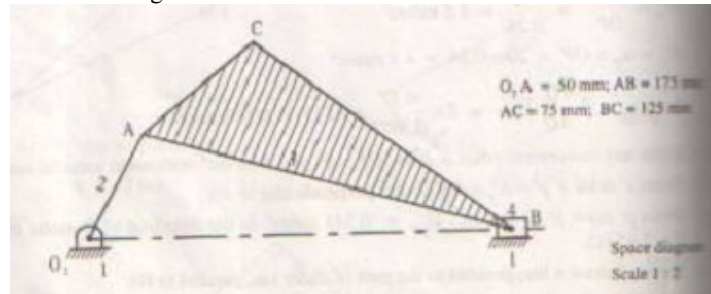

Fig. 2.1

2. The crank of a slider crank mechanism is 480mm long and rotates at 20 rad/sec in the counter clockwise direction. It has a connecting rod of 1600mm long. Determine the following when the crank is 60 degree from the inner dead centre, angular velocity of the connecting rod, the position and the velocity of a point P on the connecting rod having least absolute velocity shown in the fig.2.2

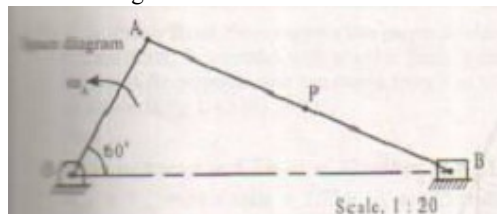

Fig. 2.2

3. The crank O2A of four bar mechanism shown in fig.2.3, is rotating clockwise at a constant speed of 100 rad/sec. Determine (a) The acceleration of the point C (b) The angular acceleration of the links 3 & 4.

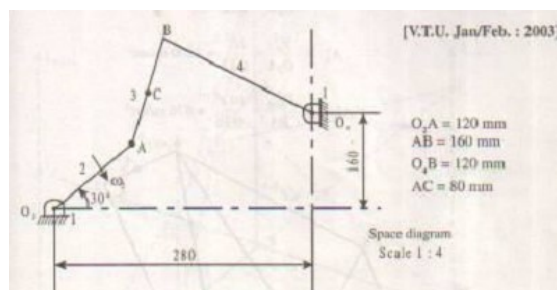

Fig. 2.3

4. A four bar mechanism ABCD is made up of four links, pin jointed at the ends. AD is fixed link which is 180 mm long. The links AB, BC, CD are 90 mm, 120mm and 120mm respectively. At certain instant, the link AB makes an



angle of 60 degree with the link AD, if the link AB rotates at uniform speed of 100 rpm clockwise determine angular velocity of links BC and CD and angular acceleration of link CD and CB as shown in fig 2.4

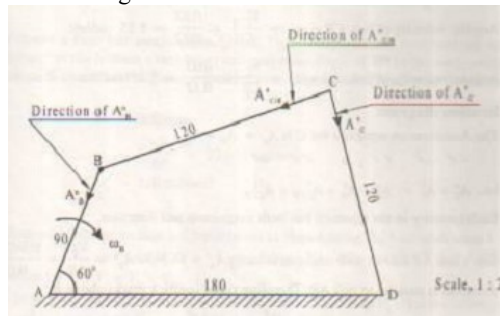

Fig. 2.4

- In a slider crank mechanism, the crank OB = 30mm and the connecting rod BC=120mm. the crank rotates at uniform speed of 300rpm clockwise. Find the crank position shown in the figure in which the crank is turned 60 degree, find a) velocity of piston C and angular velocity of connecting rod BC b) acceleration of piston C and angular acceleration of connecting rod BC as shown in fig 2.5

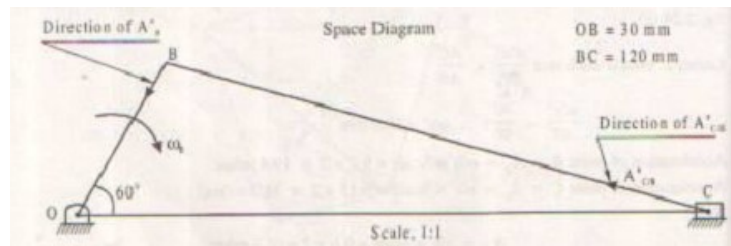

Fig. 2.5

**VELOCITY ANALYSIS BY INSTANTANEOUS CENTER METHOD:**

- State and prove Arnold-Kennedy theorem of three centers or three centers inline theorem with a neat diagram.
- Locate all the instantaneous centers for the four bar mechanism shown in the figure as shown in fig.2.6

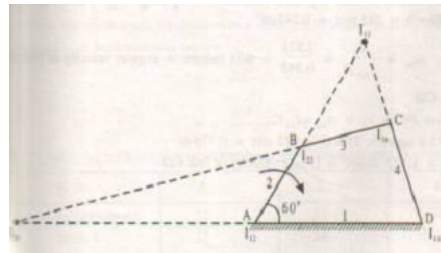

Fig. 2.6

- Locate all the instantaneous centers for the slider and crank mechanism shown in the fig.2.7

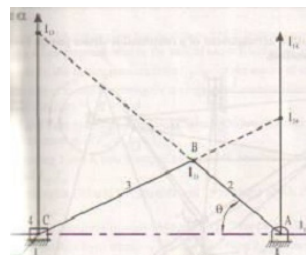

Fig. 2.7

- In a four bar mechanism shown in fig 4.4, link 2 is rotating at angular velocity ω<sub>2</sub>. locate all the instantaneous centers of the mechanism & find a) the angular speeds of link 3 & 4, the linear velocity of links 3 & 4, the linear velocities of points E & F as shown in the figure 2.8

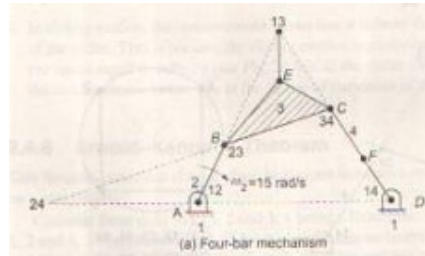

Fig. 2.8

5. Locate all the instantaneous centers of the mechanism shown in the figure 2.9

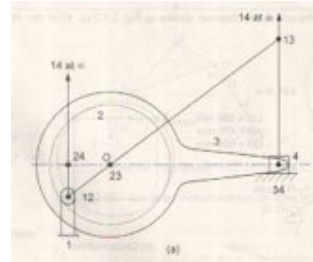

Fig. 2.9

### MODULE-3:

#### VELOCITY AND ACCELERATION ANALYSIS OF MECHANISMS (ANALYTICAL METHODS):

1. If the crank and connecting rod are 150 mm and 600 mm long respectively and the crank rotates at a constant speed of 100 rpm, determine a) velocity and acceleration of the piston b) angular velocity c) and angular acceleration of the connecting rod. The angle which the crank makes with the inner dead centre is 30 degrees.
2. The length of the connecting rod of a gas engine running at 340 rpm is 600mm and the crank is 120mm long. When the piston has moved one fourth stroke during out stroke determine a) then angular position of the crank b) the angular speed of connecting rod and c) the acceleration of the piston.
3. The length of the crank of a reciprocating engine is 120mm and its connecting rod length is 600mm it rotates at 360 rpm and at a particular instant it makes an angle of 50 degree with the inner dead center. Find a) velocity and acceleration of the piston b) velocity and acceleration of the midpoint of the connecting rod c) angular velocity and angular acceleration of the connecting rod.

### MODULE-4:

#### CAMS:

1. Enumerate commonly used types of cams.
2. Discuss briefly the types of follower displacement diagrams
3. Define the following terms related to cam (a)Lift (b)Dwell (c)Pressure angle (d)Base circle
4. Explain the following types of cams (a)D-R-D cam (b)D-R-R-D cam (c)R-R-R cam.
5. Draw the profile of the cam operating a roller reciprocating follower with the following data: minimum radius of the cam=25mm, lift=30mm, roller diameter=15mm. The cam lifts the follower for 120degree with SHM followed by a dwell period of 30degree. Then the follower lowers down during 150degree of the cam rotation with uniform acceleration and deceleration followed by a dwell period. If the cam rotates at uniform speed of 150rpm, calculate the maximum velocity and acceleration of the follower during decent period.
6. A flat faced follower is raised through a distance of 25mm in 120degree rotation of the cam, remains at rest for the next 30degree and is lowered during further 120degree rotation of the cam. The raising of the follower takes place with cycloidal motion and the lowering with uniform acceleration and deceleration. However, the uniform acceleration is 2/3 of the uniform deceleration. The least radius of the cam is 25mm. Draw the cam profile assuming clockwise rotation of the cam.
7. Draw the profile of the cam to give the following motion to the follower: Follower to move through 30mm during 180degree of cam rotation with cycloidal motion. Follower to return with cycloidal motion during 180degree of cam rotation. Base circle radius of the cam is 30mm & the roller diameter of the follower is 10mm. The axis of the roller is offset by 8mm to the right. Determine the maximum velocity & acceleration of the follower during the out stroke, when the cam rotates at 2000rpm.

### MODULE-5:

#### SPUR GEARS:

1. Two spur gears have 24 and 30 teeth of module = 10mm, standard addendum = 1 module, pressure angle = 20 degrees find a) length of arc of contact b) contact ratio.





- Two mating gears with module pitch 6mm have 20 and 50 teeth of pressure angle 20 degrees and addendum 6mm. Determine the number of pairs of teeth in contact.
- A pinion of 24 teeth drives a gear of 60 teeth at a pressure angle of 20 degrees. The pitch radius of pinion is 38mm and outside radius is 41mm. The pitch radius of the gear is 95mm and the outside radius 98.5mm. Calculate the length of path of contact and contact ration.
- Two 20 degrees involute gears in mesh have a gear ratio of 2 and 20 teeth on the pinion. The module is 5mm and the pitch line speed is 1.5 mtr per second. Assuming addendum to be equal to 1 module find a) angle turned through by pinion when one pair of teeth is in mesh and b) maximum velocity of sliding.
- Two spur gears have 30 teeth each of involute shape. The circular pitch is 25mm. Pressure angle=20 degrees, determine the addendum of wheels if arc of contact is twice the circular pitch.
- Two gear wheels mesh externally and are to give velocity ratio of 3. The teeth are of involute form of module 6mm and standard addendum=1module. Pressure angle=18 degrees, pinion rotates at 90 rpm. Find a) number of teeth on each wheel so that interference is just avoided b) length of path of contact c) maximum velocity of sliding between teeth.
- Find the minimum number of teeth to avoid under cutting when the addendum for teeth is 0.84 module. Gear ratio is 3:1; find the length of arc of contact in terms of module. Pressure angle=20 degrees.
- Two gears in mesh have a module of 8mm and a pressure angle of 20 degree. The larger gear has 57 teeth while pinion has 23 teeth. If the addenda on pinion and gear wheel are equal to 1module find a) the number of pairs of teeth in contact the angle of action of the pinion and the gear wheel.

#### GEAR TRAINS:

- Two spur gears A & B of an Epicyclic gear train is shown in the figure 4.1 have 24 and 30 teeth respectively. The arm rotates at 100 rpm clockwise. Find the speed of gear B on its own axis when gear A is fixed. If instead of being fixed the wheel A rotates at 200 rpm in ccw direction, what will be the speed of gear B. (solve it by algebraic method)

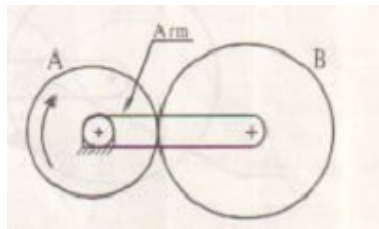

Fig. 4.1

- In an Epicyclic gear train shown in the figure 4.2, the arm A is fixed to the shaft S the wheel B having 100 teeth rotates freely on the shaft S, wheel F 150 teeth is separately driven. If the arm A runs at 200 rpm, wheel F at 100 rpm in the same direction find a) number of teeth of gear C b) speed of the wheel B. (solve it by algebraic method)

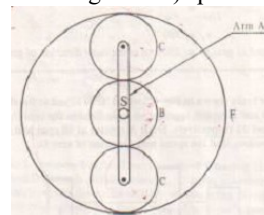

Fig. 4.2

- A fixed annular wheel B has 92 teeth. Wheel C and D have 25 and 15 teeth respectively. Wheel E has 52 teeth, if the arm A rotates at 130 rpm, what is the speed of wheel E shown in the figure 4.3.(solve it by algebraic method)

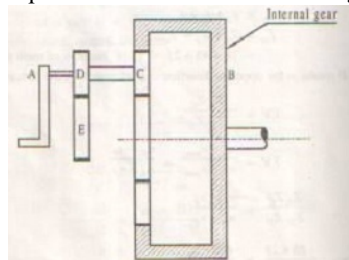

Fig. 4.3

- The gear train shown in the fig.3.4. Gear A meshes with gear B. In the compound gear B-C, gear C meshes with gear D, Rotating relative to A around the same axis of A. If the gear A is fixed, arm F is used as the driving member, determine the speed ratio  $n_D/n_F$ . Number of teeth on wheels A,B,C&D are 61,61,62&60 respectively(solve it by graphical method.)

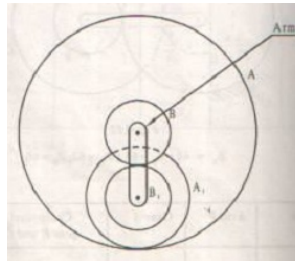

Fig. 4.4

5. An Epicyclic gear train is constructed as shown in fig 4.5. A fixed annular wheel A & a smaller concentric wheel B are connected by a compound wheel A<sub>1</sub>-B<sub>1</sub>. A<sub>1</sub> gearing with A. B<sub>1</sub> gearing with B. The compound wheel revolves on a stud which is carried around an arm which revolves about the axis A & B. A has 130 teeth, B<sub>1</sub> = 80 teeth, pitch of A & A<sub>1</sub> being twice that of pitch of B & B<sub>1</sub>. How many revolutions B will make for one revolution of the arm. (solve it by algebraic method)

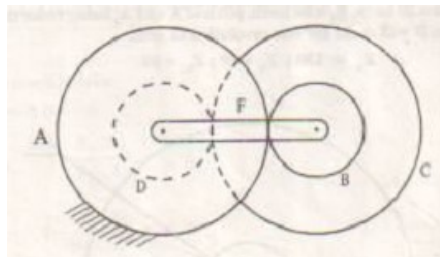

Fig. 4.5

6. An Epicyclic gear train is shown in the fig. 4.6. The wheel A is fixed & the input at the arm R is 3KW at 600rpm. Find the speed of wheel D and the torque required to hold the wheel A. Neglect frictional losses. (solve it by algebraic method)

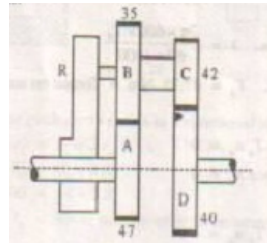

Fig. 4.6

7. In Epicyclic gear train shown in the fig 4.7, wheels A, D, E are free to rotate independently on the spindle O, while the compound wheel B-C rotates on the spindle P on the arm OP. If wheel A is given clockwise revolution of 60rpm, while gear D is given counterclockwise revolution at 300rpm, Determine the magnitude and direction of speeds of arm OP and wheel E.

Wheel	A	B	C	D	E
Teeth	12	30	14	?	?

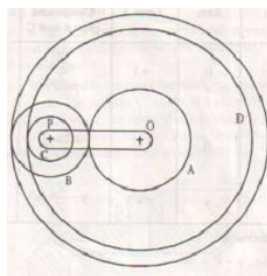





Fig. 4.7

8. Explain the term train value and velocity ratio used in gear trains.  
 9. Explain different types of gear trains with neat sketches and give examples where each one is used in practice.  
 10. Explain the sketches (a) Compound gear train (b) Reverted gear train (c) Epicyclic gear train.



## 14.0 University Result

Examination	FCD	FC	SC	% Passing
Aug-2021	23	02	--	100%

Prepared by				
				
Prof. Mahantesh Tanodi	Prof. D. N. Inamdar	HOD	Principal	



<b>Subject Title</b>	<b>COMPUTER AIDED MACHINE DRAWING</b>		
<b>Subject Code</b>	18ME46A	<b>IA Marks</b>	40
<b>No of Lecture Hrs + Tutorial Hrs / Week</b>	01+ 04	<b>Exam Marks</b>	60
<b>Total No of Lecture + Practical Hrs</b>	50	<b>Exam Hours</b>	03
<b>CREDITS – 03</b>			

**FACULTY DETAILS:**

<b>Name:</b> Prof. Mahantesh Tanodi	<b>Designation:</b> Asst. Professor	<b>Experience:</b> 10 Years
<b>No. of times course taught:</b> 08	<b>Specialization:</b> Machine Design	

**1.0 Prerequisite Subjects:**

Sl. No	Branch	Semester	Subject
01	Mechanical Engineering	I/II	CAED
02	Mechanical Engineering	III	Mechanical Measurements

**2.0 Course Objectives**

1. To acquire the knowledge of CAD software and its features.
2. To inculcate understanding of the theory of projection and make drawings using orthographic projections and sectional views
3. To familiarize the students with Indian Standards on drawing practices.
4. To impart knowledge of thread forms, fasteners, keys, joints and couplings.
5. To make the students understand and interpret drawings of machine components so as to prepare assembly drawings either manually and using CAD packages.
6. To acquire the knowledge of limits fits and tolerance pertaining to machine drawings.

**3.0 Course Outcomes**

Having successfully completed this course, the student will be able to draw and use modeling software's to generate

CO	Description
C206A.1	Have hands on experience on mechanical modeling software.
C206A.2	Draw true shape of sections of polyhedrons.
C206A.3	Visualize and draw orthographic views of simple machine components.
C206A.4	Understand and draw various thread forms.
C206A.5	Understand and draw orthographic views of assembly of fasteners as per BIS.
C206A.6	Understand and draw orthographic views of various riveted joints, cotter/knuckle joints and couplings as per BIS.
C206A.7	Visualize and prepare models of given detailed parts of machine component and its assembly with bill of materials and specifications.

**4.0 Course Content**

**PART A**



**Introduction:** Review of graphic interface of the software. Review of basic sketching commands and navigational commands. Starting a new drawing sheet. Sheet sizes. Naming a drawing, Drawing units, grid and snap.

Conversion of pictorial views into orthographic projections of simple machine parts (with and without section). Hidden line conventions. Precedence of lines. **(3 Hours)**

**Sections of Solids:** Sections of Pyramids, Prisms, Cubes, Tetrahedrons, Cones and Cylinders resting only on their bases (No problems on axis inclinations, spheres and hollow solids). True shape of sections. Conversion of pictorial views into orthographic projections of simple machine parts. Hidden line conventions. Precedence of lines. **(3 Hours)**

**Conversion of pictorial views into orthographic projections** of simple machine parts (with section planes indicated on the part). **(3 Hours)**

**Thread Forms:** Thread terminology, sectional views of threads. ISO Metric (Internal & External), BSW (Internal & External) square and Acme. Sellers thread, American Standard thread.

**Fasteners:** Hexagonal headed bolt and nut with washer (assembly), square headed bolt and nut with washer (assembly) simple assembly using stud bolts with nut and lock nut. Flanged nut, slotted nut, taper and split pin for locking, counter sunk head screw, grub screw, Allen screw. **(3 Hours)**

#### PART B

**Keys:** Parallel key, Taper key, Feather key, Gib-head key and Woodruff key.

**Joints:** Cotter joint (socket and spigot), knuckle joint (pin joint) for two rods. **(6 Hours)**

**Couplings:** Split Muff coupling, Protected type flanged coupling, pin (bush) type flexible coupling, and universal coupling (Hooks' Joint) **(6 Hours)**

#### PART C

**Limits, Fits and Tolerances:** Introduction, Fundamental tolerances, Deviations, Methods of placing limit dimensions, machining symbols, types of fits with symbols and applications, geometrical tolerances on drawings. Standards followed in industry. **(1 Hours)**

**Assembly Drawings:** (Part drawings shall be given)

1. Plummer block (Pedestal Bearing)
2. Lever Safety Valve
3. I.C. Engine connecting rod
4. Screw jack (Bottle type)
5. Tailstock of lathe
6. Machine vice
7. Tool head of shaper **(25 Hours)**

### 5.0 Relevance to future subjects

Sl No	Semester	Subject	Topics
01	VIII	Project work	Drawings, Part Modeling
02	V/VI	Design of Machine Elements I/II	Fasteners, Keys and Joints, Rivets and Assembly drawings

### 6.0 Relevance to Real World

SL.No	Real World Mapping
01	Industrial drawings and design of various components
02	Model creation for analysis
03	Development of a software applications

### 7.0 Gap Analysis and Mitigation

Sl. No	Delivery Type	Details
01	Tutorial	Topic: Lettering, Line, Methods of dimensioning



02	NPTEL	Assembly Application
----	-------	----------------------

## 8.0 Books Used and Recommended to Students

<b>Text Books</b>
<ol style="list-style-type: none"> <li>1. 'A Primer on Computer Aided Machine Drawing-2007', Published by VTU, Belgaum.</li> <li>2. 'Machine Drawing', N.D.Bhat&amp;V.M.Panchal, Published by Charotar Publishing House, 1999.</li> <li>3. 'Machine Drawing', N.Siddeshwar, P.Kannaiah, V.V.S. Sastri, published by Tata Mc.Grawhill, 2006.</li> </ol>
<b>Reference Books</b>
<ol style="list-style-type: none"> <li>1. "A Text Book of Computer Aided Machine Drawing", S. Trymbakaa Murthy, CBS Publishers, New Delhi, 2007.</li> <li>2. 'Machine Drawing', K.R. Gopala Krishna, Subhash publication.</li> </ol>
<b>Additional Study material &amp; e-Books</b>
<ol style="list-style-type: none"> <li>1. "Machine Drawing", K.L.Narayana, P.Kannaiah and K. Venkata Reddy, 3rd Edition, New Age Publishers, 2007.</li> <li>2. "Machine Drawing", N D Bhatt, 44th Edition, Charotar Publishers, 2009.</li> <li>3. "Machine Drawing", Dhawan, S.Chand Publications, 2005.</li> <li>4. "Machine Drawing", P.S.Gill, S.Chand Publications, 2005.</li> </ol>

## 9.0 Relevant Websites (Reputed Universities and Others) for Notes/Animation/Videos Recommended

<b>Website and Internet Contents References</b>
<ol style="list-style-type: none"> <li>1) <a href="https://hareeshang.wordpress.com/tutorials/camd/">https://hareeshang.wordpress.com/tutorials/camd/</a></li> <li>2) <a href="http://m.noteboy.in/vtufly/machine%20drawing.pdf">http://m.noteboy.in/vtufly/machine%20drawing.pdf</a></li> <li>3) <a href="https://www.edx.org/school/iitbombayx?utm_source=bing&amp;utm_medium=cpc&amp;utm_term=iit-bombay&amp;utm_campaign=partner-iit-bombay">https://www.edx.org/school/iitbombayx?utm_source=bing&amp;utm_medium=cpc&amp;utm_term=iit-bombay&amp;utm_campaign=partner-iit-bombay</a></li> <li>4) <a href="http://www.vlab.co.in/">http://www.vlab.co.in/</a></li> </ol>

## 10.0 Magazines/Journals Used and Recommended to Students

Sl.No	Magazines/Journals	website
1	Journal of Aircraft	<a href="http://arc.aiaa.org/loi/ja">http://arc.aiaa.org/loi/ja</a>
2	International Journal of Solids and Structures	<a href="http://www.sciencedirect.com/science/journal/00207683">http://www.sciencedirect.com/science/journal/00207683</a>
3	Journal of Manufacturing Science and Engineering	<a href="http://manufacturingscience.asmedigitalcollection.asme.org/issue.aspx?journalid=125&amp;issueid=27340">http://manufacturingscience.asmedigitalcollection.asme.org/issue.aspx?journalid=125&amp;issueid=27340</a>
4	<b>American Fastener Journal</b>	<a href="http://www.fastenerjournal.com/">http://www.fastenerjournal.com/</a>

## 11.0 Examination Note

### Scheme of External Examination:

Two questions to be set from each Part A, part B and Part C. Student has to answer one question each from Part A and Part B for 25 marks each and one question from Part C for 50 marks.

### INSTRUCTION FOR COMPUTER AIDED MACHINE DRAWING (15ME36A/46A) EXAMINATION

1. No restriction of timing for sketching/ computerization of solutions. The total duration is 3 hours.
2. It is desirable to do sketching of all the solutions before computerization.
3. Drawing instruments may be used for sketching.
4. For Part A and Part B, 2D drafting environment should be used.
5. For Part C, 3D environment should be used for parts and assembly, and extract 2D views of assembly.

**Internal Assessment: 20 Marks**



Sketches shall be in sketch books and drawing shall through use of software on A3/A4 sheets. Sketch book and all the drawing printouts shall be submitted.

**Scheme of Evaluation for Internal Assessment (40 Marks)**

- (a) Class work (Sketching and Computer Aided Machine drawing printouts in A4/A3 size sheets): 20 Marks.
- (b) Internal Assessment test in the same pattern as that of the main examination: 20 marks.

**12.0 Course Delivery Plan**

Module	Lecture No.	Content of Lecturer	% of Portion
<b>PART - A</b>			
<b>MODULE 1</b>	1	<b>INTRUCTION TO COMPUTER AIDED SKETCHING:</b> Review of graphic interface of the software. Review of basic sketching commands and navigational commands.	12.5%
	2	Starting a new drawing sheet. Sheet sizes. Naming a drawing, Drawing units, grid and snap.	
	3	<b>Sections of Solids:</b> Sections of Pyramids, Prisms, Cubes, Tetrahedrons, Cones and	
	4	Cylinders resting only on their bases (No problems on, axis inclinations, spheres and	
	5	hollow solids). True shape of sections	
	6		
	7	<b>Orthographic Views:</b> Conversion of pictorial views into orthographic projections. Of	
	8	<b>simple machine parts</b> with or without section. (Bureau of Indian Standards	
9	conventions are to be followed for the drawings) Hidden line conventions. Precedence		
10	of lines.		
<b>MODULE 2</b>	11	<b>Thread Forms:</b> Thread terminology, sectional views of threads. ISO Metric (Internal	12.5%
	12	& External) BSW (Internal & External) square and Acme. Sellers thread, American	
	13	Standard thread.	
	14		
	15	<b>Fasteners:</b> Hexagonal headed bolt and nut with washer (assembly), square headed bolt	
	16	and nut with washer (assembly) simple assembly using stud bolts with nut and lock nut.	
	17	Flanged nut, slotted nut, taper and split pin for locking, counter sunk head screw, grub	
18	screw, Allen screw.		
<b>PART – B</b>			
<b>MODULE 3</b>	19	<b>Keys:</b> Parallel key, Taper key, Feather key, Gib-head key and Woodruff key.	12.5%
	20		
	21		
	22		
	23	<b>Joints:</b> Cotter joint (socket and spigot), knuckle joint (pin joint) for two rods.	
	24		
	25		
26			
<b>MODULE 4</b>	27	<b>Couplings:</b> Split Muff coupling, Protected type flanged coupling, pin (bush)	12.5%
	28	type flexible coupling, and universal coupling (Hooks' Joint)	
	29		
	30		
	31		
	32		
	33		
34			
<b>PART-C</b>			
<b>MODULE 5</b>	35	<b>Limits, Fits and Tolerances:</b> Introduction, Fundamental tolerances, Deviations,	50%
	36	Methods of placing limit dimensions, Types of fits with symbols and applications,	
	37	Geometrical tolerances on drawings, Standards followed in industry	
	38	1. Plummer blocks (Pedestal Bearing).	
	39		
	40	2 Rams bottom safety valve.	
41	3. I.C. Engine connecting rod		



42		
43		
44	4. Screw jack (Bottle type).	
45		
46	5. Tailstock of lathe.	
47	6. Machine vice.	
48		
49		
50	7. Tool Head of a shaper	

### 13.0 Assignments, Pop Quiz, Mini Project, Seminars

Sl. No.	Title	Outcome expected	Allied study	Week No.	Individual / Group activity	Reference: book/website /Paper
1	Assignment 1: University Questions on Section of solids and Orthographic views	Students study the Topics and write the Answers. Get practice to solve university questions.	Module 1 of the syllabus	2	Individual Activity. Printed solution expected.	Book 1, 2 of the reference list. Website of the Reference list
2	Assignment 2: University Questions on Thread forms and fasteners	Students study the Topics and write the Answers. Get practice to solve university questions.	Module 2 of the syllabus	4	Individual Activity. Printed solution expected.	Book 1, 2 of the reference list. Website of the Reference list
3	Assignment 3: University Questions on Keys, Joints and Riveted joints	Students study the Topics and write the Answers. Get practice to solve university questions.	Module 3 of the syllabus	6	Individual Activity. Printed solution expected.	Book 1, 2 of the reference list. Website of the Reference list
4	Assignment 4: University Questions Couplings	Students study the Topics and write the Answers. Get practice to solve university questions.	Module 4 of the syllabus	8	Individual Activity. Printed solution expected.	Book 1, 2 of the reference list. Website of the Reference list
5	Assignment 5: University Questions on Assembly Drawings	Students study the Topics and write the Answers. Get practice to solve university questions.	Module 5 of the syllabus	10	Individual Activity. Printed solution expected.	Book 1, 2 of the reference list. Website of the Reference list
6	Mini Project Rivets based for the students groups	Students study the Rivets applications from Real World Example view. Gain Knowledge of Rivets Applications.	Syllabus with Real World Mapping	12	Group Activity. Student Group need to perform Project and do a brief Report	All Books / paper Resources / Study Material. All Internet / Web resources.

### 14.0 QUESTION BANK

#### MODULE 1: SECTIONS OF SOLIDS





### Section of pyramids

1. An equilateral triangular pyramid of base side, 40 mm and height 70 mm rests with its base on the HP such that one of its slant edges parallel to VP. A section plane perpendicular to VP and inclined at  $63^\circ$  to HP cuts the pyramid by passing through one of its lateral faces at a height of 9mm above the HP. Draw the FV, sectional top view and sectional side view along with the cut solid.
2. An equilateral triangular pyramid of 30mm side of base and axis 60mm long rests with its base on HP such that one of the base edges is inclined at  $45^\circ$  to the VP and nearer to it. It is cut by a section plane inclined at  $60^\circ$  to the HP and perpendicular to the VP, intersecting the axis at 40mm from the vertex. Draw the FV, sectional views from the top and right side along with the cut solid. Also project the true shape of section.
3. Fig p2.3 shows the sectional side view of an equilateral triangular truncated pyramid. Determine the true shape of section. Also find the inclination of the section plane with reference plane and size of the pyramid.
4. A triangular pyramid of base sides 50mm and axis 80mm long stands vertically with its base on the HP, such that one of the base edges is perpendicular to VP. A sectional plane perpendicular to VP and parallel to one of the slant edges of the pyramid passes at distances of 25mm from it. Draw the sectional top view and true shape of section. Also determine the inclination of the section plane with the reference plane.
5. A triangular pyramid of 50mm side of base and axis length 80mm rests on its base on the HP with one of its base edges perpendicular to the VP. A section plane perpendicular to the VP and parallel to one of the lateral faces of the pyramid passes through at a distance of 25mm from the apex. Draw the front view, sectional top view and true shape of section. Determine the inclination of the section plane with the reference plane.
6. A triangular pyramid base 50mm sides and axis 80mm long, resting on its base on the ground with one of its base edges perpendicular to VP, is cut by two section planes, both perpendicular to the VP and are inclined at  $45^\circ$  to the HP, meet the axis at its mid-height. Both the section planes lie on either side of the axis and lean towards the base of the pyramid. Draw the front view, sectional top view and the combined true shape of section.
7. A triangular pyramid of base sides 50mm and 80mm long, resting on its base on the ground with one of its base edges perpendicular to the VP, is cut by two section planes, both perpendicular to the VP and are inclined at  $45^\circ$  to the HP, meet the axis at its mid-height. Both the section planes lie on either side of the axis and lean upwards. Draw the front view, sectional top view and the combined true shape of section.
8. A triangular pyramid, base 40mm sides and axis 60mm long, resting on its base on the HP with one of its base edges parallel to the VP. A section plane passing through one of the base corners of the pyramid and the two slant edges at 20mm and 30mm above the HP cuts the pyramid. Draw the front view, sectional top view and true shape of section. Determine the inclination of the section plane with the reference plane.
9. A triangular pyramid of base sides 40mm and axis length 60mm is resting on its base on the ground with one of its base edges parallel to the VP and nearer to it. It is cut by two section planes both perpendicular to the VP and inclined to HP and meet at one of the base corners of the pyramid which is at equidistant from the other two base corners. One of the section planes is inclined at  $45^\circ$  to the HP and cuts the left slant edge while the other section plane is inclined at  $60^\circ$  to the HP and cuts the right end slant edge. Draw the front view, sectional top view and true shape of section.
10. A triangular pyramid of base sides 50mm and axis 65mm long rest vertically on its base with one of the base edges inclined at  $30^\circ$  to the VP and from it is such a way that the apex will be at 35mm in front of the VP. A HT inclined at  $45^\circ$  to XY line cuts the pyramid at 10mm in front of the axis. Both the section plane and the reference base edge of the pyramid lean towards right side. Draw the resulting sectional view the true shape section.
11. A square pyramid of base side 45mm and axis length 70mm rests on its base on the HP in such way that all of its base edges are equally inclined to the VP. It is cut by a section plane perpendicular to the VP, inclined at  $45^\circ$  to the HP and bisecting the axis. Draw the sectional top view sectional side view and true shape of section.
12. A square pyramid side of base 40mm and altitude 60mm has its base on the HP with an edge of base inclined at  $30^\circ$  to the VP. It is cut by a VT, passing through one of the extreme base corners and the center of gravity of the pyramid. Draw the sectional top view and true shape of section.
13. A square pyramid of base side 35mm and axis length 65mm is resting on the HP on its base with a side of base inclined at  $30^\circ$  to the VP. It is cut by a plane perpendicular to both the HP and VP and is 10mm away from the axis. Draw its top view, front view and true shape of section.
14. A hexagonal pyramid side of base 30mm and altitude 70mm is rests with its base on the HP and with a side of base parallel to the VP. It is cut by a cutting plane inclined at  $35^\circ$  to the HP and perpendicular to the VP and is bisecting the axis. Draw the front view, the sectional view looking from the top and true shape of section.
15. A pentagonal pyramid side of base 40mm and altitude 70mm is rests with its base on the HP and with a side of base parallel to the VP and 25mm from it. It is cut by a horizontal cutting plane and is bisecting the axis. Draw the front view and the sectional view looking from the top.

### Sections of tetrahedrons

1. A tetrahedron of sides 60mm is resting on the HP on one of its faces, with an edge perpendicular to the VP and the nearest base corner is 25mm in front of it. A VT, whose angle of inclination  $55^\circ$  with the reference line XY cuts solid by passing through the axis at a height of 40mm above the base. Draw the resulting sectional view and true shape of section.



2. Fig p.16 shows two concentric equilateral triangles. It is the resulting sectional view of a tetrahedron resting on its base on the HP which is cut by a VT. Complete the projections of the cut solids. Determine the height of the full solid and the position of the section plane.

#### Sections of cones

1. A cone of base diameter 50mm and axis length 65mm rests with its base on the HP. Draw the true shape of section made by a section plane perpendicular to the VP and inclined to the HP at  $50^\circ$  and passing through an end point on the circumference of the base circle of the cone.
2. A cone of base diameter 50mm is resting on its base on the HP. It is cut by section plane perpendicular to the VP, so that the true shape of cut section is a triangle of base 40mm and altitude 63mm. locate the section plane and determine the angle of inclination of the VT with the reference line XY. Draw the front view. Determine the height of the cone. Also draw the apparent section and true shape of section.
3. A cone of base diameter 50mm and height 60mm stands with its base on the HP. It is cut by a VT inclined at  $70^\circ$  to the reference line XY and is passing through the apex of the cone. Draw its front view, sectional top view and true shape of section.
4. A cone of diameter of base 60mm and axis length 70mm is resting on its base on the ground. It is cut by two section planes. One is parallel to contour generator and 10mm away from it, while the other is parallel to the opposite contour generator. Both the cutting planes lean towards the base, intersecting each other on the axis of the cone. Draw the sectional plan, elevation and the left side view. Also draw the true shape of section with respect to any one of the section planes. Name the curve thus obtained.
5. A cone of diameter of base 50mm and axis length 70mm is standing with its base on the HP. It is cut by a section plane inclined at  $40^\circ$  to the VP and perpendicular to the HP cut s the cone at a distance 10mm in front of its axis. Draw the top view, sectional front view and true shape of section.

#### Sections of cubes

1. A cube of 45mm edge rests on one of its faces on the ground with its base edges equally inclined to the VP. A VT perpendicular to one of the solid diagonals cuts the solids through one of its base corners. Draw the sectional top view, true shape of section and determine the inclination of the section plane with the reference plane.
2. A hexahedron of 50mm side rests with a face on the HP such that one of its vertical faces is inclined is  $30^\circ$  to the VP. A section plane parallel to the VP and perpendicular to the HP cuts the cube at a distance of 20mm from the farthest vertical edge from the observer. Draw its top view, sectional front view and true shape of section.
3. The true shape of section of a hexahedron is an equilateral triangle of side 50mm. Position the cube of suitable size on the HP and locates the VT. Determine the inclination of section plane with HP and size of the cube. Also draw the sectional top view and true shape of section.
4. A cube of 40mm side is cut by a VT, so that the true shape of section is an equilateral triangle of sides of maximum length. Draw the sectional top view and true shape of section. Determine the inclination plane to HP and measure the length of the sides of the equilateral triangle.
5. The true shape of the section of a cube is a rhombus having diagonals of 60mm and 50mm. Draw the projections of the cube keeping it on base using a suitable position. Determine the size of the cube and the inclination of AIP with the HP. Also check the true shape of section.
6. A hexahedron of 40mm sides is cut by a section plane, so that the true shape of section is a rhombus of sides of maximum length. Draw the sectional top view and the true shape of section. Also find the inclination of the section lane with the reference plane and the size of the rhombus.

#### Sections of prisms

1. A Rectangular prism of height 75mm and cross section 60X37.5mm is resting on its base on the HP with one of its shorter base edges parallel to VP. A VT whose width between its ends is equal to the longer base edge cuts the prism through one of the extreme base edges and pass through the lateral face opposite to that base edge. Draw the front view and true shape of the section. Measure the inclination of the section plane and sides of the true shape.
2. A rectangular prism of height 80mm and cross section 48X32mm is resting on the HP with its base. It is cut by a section plane in such a way that the true shape of section is a square of sides of maximum dimension. Draw the front view and determine the inclination of section plane to the reference plane. Also draw the sectional top view and true shape of section.
3. A square prism, sides of square faces 40mm and height 80mm rests with its base on the HP with a vertical face inclined at  $30^\circ$  to the VP. It is cut by a plane inclined at  $50^\circ$  to the VP and perpendicular to the HP and is 15mm from axis nearer to the observer. Both that inclined faces and the section plane lean towards the same direction. Draw its top view, sectional front view and true shape of section.
4. An equilateral triangular prism of 60mm base side and axis length 100mm is resting on the HP with its axis vertical and one of its base edges parallel to the VP and nearer to it. It is cut by an inclined section plane perpendicular to the HP and  $60^\circ$  to the VP and 10mm in front of the axis. Draw the sectional front view and true shape of section.

#### Sections of cylinders



1. A cylinder of base diameter 50mm and 70mm is resting with its base on the HP. A section plane inclined at  $50^\circ$  to the VP and perpendicular to the HP cuts the solid at 10mm in front of it. Draw its top view, sectional front view and true shape of section.
2. A cylinder of base diameter 50mm and axis 70mm is resting on the HP with its axis vertical. A section plane perpendicular to both the HP and the VP cuts the cylinder at 15mm right of the axis. Draw the projections of the cylinder showing the true shape of section.
3. A cylinder of diameter of base 45mm and height 70mm long rests on its base on the HP. It is cut by a plane perpendicular to the VP and inclined at  $30^\circ$  to the HP and meets the axis at a height of 30mm above the base. Draw the front view, sectional top view and true shape of section.
4. A cylinder, 60mm diameter of base and axis 80mm long rests with its base on the HP. A section plane passing through one of its extreme end points on the circumference of its base circle and a point on the axis at 49mm from the base cuts the cylinder. Determine the inclination of the section plane with reference plane. Also draw the sectional top view and the sectional side view.
5. A cylinder of base diameter 50mm and axis 100mm long rests on its base on the HP. A VT cuts the cylinder to the HP through the mid point of the axis. Draw the front view, sectional plan and true shape of section.
6. A triangle of base 60mm and height 75mm is the front view of a cut cylinder of base diameter 60mm and height 75mm sectioned by two cutting planes. Draw the sectional views looking from the top and right sides. Also project one of the true shapes of section and determine the inclinations of the section planes.

### ORTHOGRAPHIC VIEWS

1. Draw the following views of machine components Sectional FV, TV, Left side view.

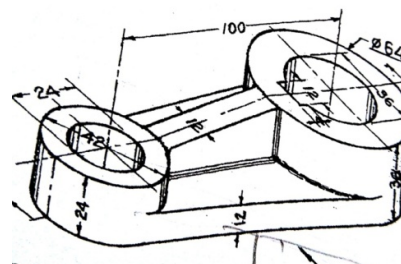
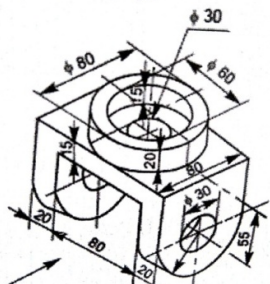
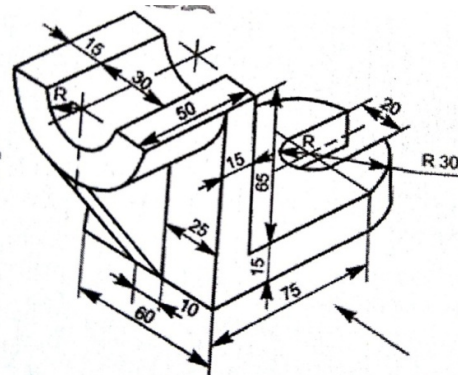
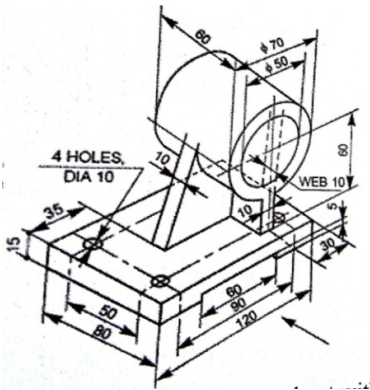

### MODULE 2. LINEAR CONTACTS:

1. Draw neat sketches to indicate conventional representation of the following:
  - i) BSW thread having pitch 50mm.
  - ii) Acme thread pitches 60mm. Show at least 3 threads in section.
2.
  - i) Draw proportionate sketch of the locking device for a nut, use 20mm diameter Bolt using split pin.
  - ii) Sketch any one type of Grub screw.
3. Draw neat and proportionate sketches of the following.
  - i) ISO screw thread profile of pitch 50mm indicate all proportions and dimensions.
  - ii) Two views of hexagonal headed bolt with nut for a 30mm diameter bolt. Take length of bolt equal to 125mm.
  - iii) Castle nut.
4. Make neat and proportionate sketches of the following.
  - i) Acme thread,
  - ii) Two view of M20 hexagonal bolt with flanged nut. Consider length of the Shank as 150mm,
  - iii) Counter sunk head screw.



5. Draw a proportional neat sketch of a Knuckle joint to connect two rods of 20mm dia. Indicate all the proportions with dimensions.
6. Sketch a proportionate sectional front view of a knuckle joint to connect two rods of diameter 20mm. Indicate a few important dimensions in terms of diameter 'd'.

#### FASTNERS:

1. Draw two views of
  - a. Hexagonal bolt and
  - b. Square headed bolt of size 25mm dia and 100mm long. Indicate all the dimensions.
2. Draw the three views of an ISO-threaded hexagonal bolt 140mm long, 24mm diameter and a threaded length of 60mm, with a hexagonal nut. Indicate all the proportions and actual dimensions.

#### PART-B

#### MODULE 3: KEYS AND JOINTS:

1. Draw the two views of a sunk key fastening a boss to a shaft of 40mm diameter. The noncircular views of the assembly should be shown in half section. Indicate the actual dimensions and empirical proportions of the key.
2. Sketch to 1:1 scale, inserting all the dimensions, two views of a wheel boss fixed to a shaft by means of a sunk gib-head key using the following dimensions. Diameter of the shaft=50mm, diameter of boss=100mm, length of boss=75mm.  
Using empirical proportions for the gib-head key, the view showing the length of the key should be drawn in section. Indicate the actual dimensions of the key.
3. Draw in assembly the flat and hollow saddle keys for 40mm diameter shaft. Use empirical proportions. The drawing should be completely dimensioned. Draw the feather key locked to a shaft of 40mm diameter fastened to a boss. Show the non circular view of the assembly in half section. Fully dimension the drawing.
4. Sketch to 1:1 scale, inserting dimensions, two views of a boss fixed to a shaft by means of woodruff key. Diameter of the shaft is 50mm. diameter of the boss is 100mm. the length of the boss is 75mm.

#### MODULE 4: COUPLINGS:

1. Draw i) half sectional front view with top half section and ii) Side view of a protected type flange coupling to connect two shafts of diameter 25mm each.
2. Prepare free hand sketches of a protected type flange coupling as per instruction given below: i) Sectional elevation with top half in section. ii) Right view. Take diameter of shaft  $D=30\text{mm}$  and a scale of 1:1. Indicate important dimensions on the sketches.
3. Prepare free hand sketches (half sectional front view-top half) of a protected type flange coupling for a shaft of 30mm dia adopt. Standard proportions add side view. Mark important dimensions/proportions on the views.
4. Draw to 1:1 scale, the following views of a protected type flange coupling (diameter of shaft=20mm):
  - i) Front view with top half section.
  - ii) Left view looking from the nut end. Indicate important dimensions, add parts list.
5. Draw the following views of a UNIVERSAL COUPLING used to connect two rods of diameter 20mm:
  - i. Sectional front view.
  - ii) Profile view.
6. Draw a free hand sketch of a flanged nut assuming the nominal diameter to be 20mm.
7. Draw a neat and proportionate sketch of a protected type of flanged coupling to connect two shafts of 25mm showing the following views.
  - i) Front view with top half in section.
  - ii) Simple top view.
  - iii) Right side view.
8. draw i) Half sectional front view, with top half in section ii) side view of a bushed pin type flange coupling to connect two shafts, each of diameter 30mm.
  - i) Prepare a neat and proportionate free hand sketch of a bushed-pin type of flexible coupling to connect two shafts of 20mm diameter for the following views: i) Front view with top half in section. ii) Side view from pin-head end.
2. Sketch neat proportional half sectional front view of protected type flanged coupling to connect two shafts of 20mm diameter. Indicate all proportions with dimensions. Prepare parts list.
3. Sketch the following view of a Flanged coupling (protected type) to connect two shafts of 20mm diameter.
  - i) Front view with top half in section.
  - ii) Left side view.
4. Sketch half sectional front view of a flange coupling unprotected type to connect two shafts 20mm diameter. Indicate all proportions. Add parts list.
5. Sketch sectional front view of a **Universal** coupling to connect two rods of diameter 30mm. indicate all dimensions, add parts lists.
6. Draw the following, views of pin type flexible coupling, to connect to shafts of 30mm diameter.



- i) Front view with top half in section,
  - ii) Side view from the pin end.
7. Sketch the sectional front view of a flexible coupling to connect two shafts of 25mm dia with all dimensions.

**PART-C**

**MODULE 5 : LIMITS, FITS AND TOLERANCES**

1. Define Limits, Fits and Tolerances
2. Explain with neat sketch Types of fits with symbols and applications

**ASSEMBLY DRAWINGS: (Part drawings should be given)**

1. Details of a “PLUMMER BLOCK” is shown in fig. Assemble the parts and draw the following views with all important dimensions.i) Left half sectional view.ii) Top view.
2. Fig. shows the details of “SCREW JACK”. Assemble the parts and draw the following views i) Front view showing right half in section and ii) top view.
3. Fig. Shows the details of “SCREW JACK”. Assemble the parts and draw the following views i) Sectional Front view and ii) Top view.
4. Fig. shows the details of a “Ramsbottom safety valve”. Assemble the parts and draw the following views. Dimension the drawings.i) Front view in section.ii) Top view.
5. Details of a “PLUMMER BLOCK” are shown in fig.1.2. Assemble the parts and draw the following views of the assembly.i) Front view showing right half in section.ii) Top view.
6. Fig. shows the details of an I.C Engine Connecting Rod. Assemble the parts and draw the following views. Dimension the drawings.i) Front view with top half in section.ii) Top view.
7. Fig. shows the details of a Tail-Stock of a Lathe. Assemble the parts and draw.i) Sectional Front view.ii) Top view.
8. Fig. shows the details of a “CONNECTING ROD”. Assemble the parts and draw the following views. Dimension the drawings .i) Front view and ii) Top view.

**15.0 University Result**

Examination	FCD	FC	SC	% Passing
Aug-2021	23	02	--	100%

Prepared by	Checked by		
<b>Prof. Mahantesh Tanodi</b>	<b>Prof. D. N. Inamdar</b>	<b>HOD</b>	<b>Principal</b>